

A large, modern multi-story building under construction. The building features a mix of dark grey, white, and red panels. A prominent red tower crane stands in the center. The ground floor has a dark, textured facade with large windows. In the foreground, there is a parking lot with several cars and a white van. The sky is clear and blue. A semi-transparent white banner with the text 'OLYMPIA WEST POINT' is overlaid across the middle of the image.

OLYMPIA WEST POINT



ПРЕД АКТ 16



ЗА ПРОЕКТА

Olympia West Point е луксозно изпълнение, съчетаващо съвременните изисквания за естетика в модерната архитектура и спокойствие, осигурено от технологии с повече зеленина и свободни пространства. Съществена част от проекта е добре обмислената външна и вътрешна инфраструктура. Комплексът се състои от 4 секции, свободни апартамент има в 3 от тях. Таксата поддръжка на комплекса е в размер на 38 лв без ДДС или 45 лв с ДДС за всеки апартамент, независимо от размера му. Освен това сградата разполага с три нива подземни паркоместа.



ЛОКАЦИЯ

Сградата "Olympia west Point се намира" до МОЛ "Пловдив" (бул. "Пещерско шосе" 38) в един от най-озаленените и търсени райони в гр. Пловдив - ж.к. "Отдых и култура". Сградата ще е с удобно разположение до хранителни супермаркети "Lidl" и "Kaufland", детски градини, училища, обществени паркинги, паркове и велоалеи. В близост са и Гребната база, тенис кортове и футболни игрища. Локацията е сред най-предпочитаните за инвестиция, тъй като се намира в близост до Медицинския университет и всички големи болници в града.

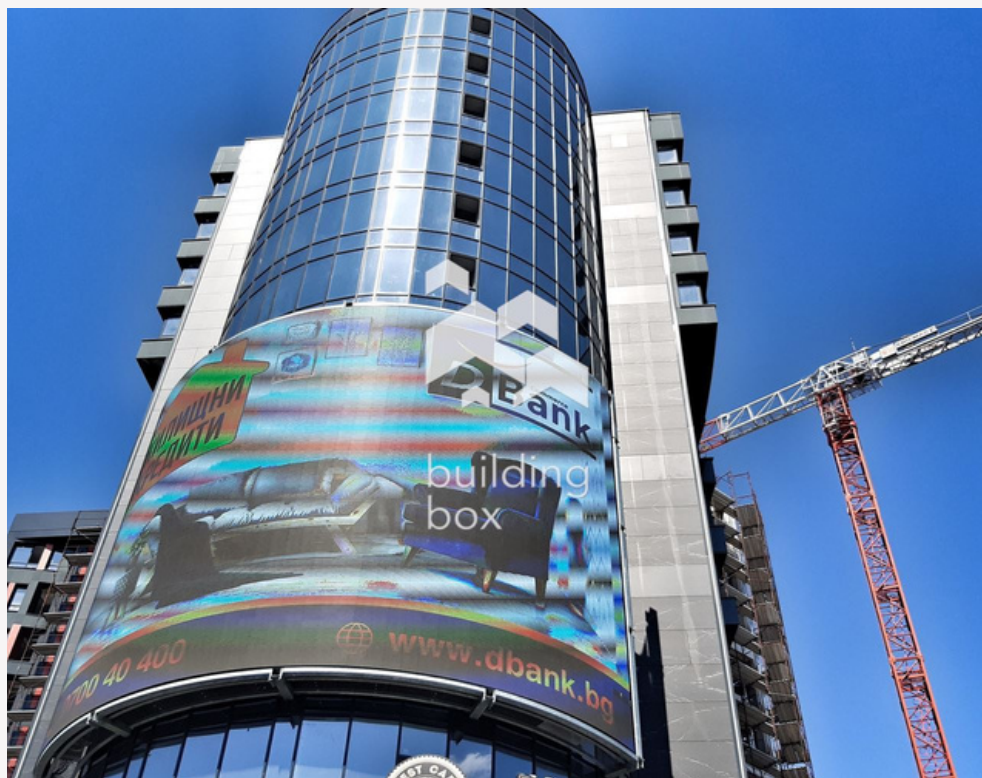

OLYMPIA WEST POINT

1000 – 1450 евро/кв



Добра
локация



Надежден
инвеститор



Пред
Акт 16

Налични са много хубави **студиа** на цени от 49 000€ до 70 000€
Двустайни апартаменти - от 80 000€ до 110 000€
Тристаен апартамент (останал е Г28)
Четиристайни - от 149 000 до 163 000 €



ETAЖ 3

West Point

HAPPY GOLDEN

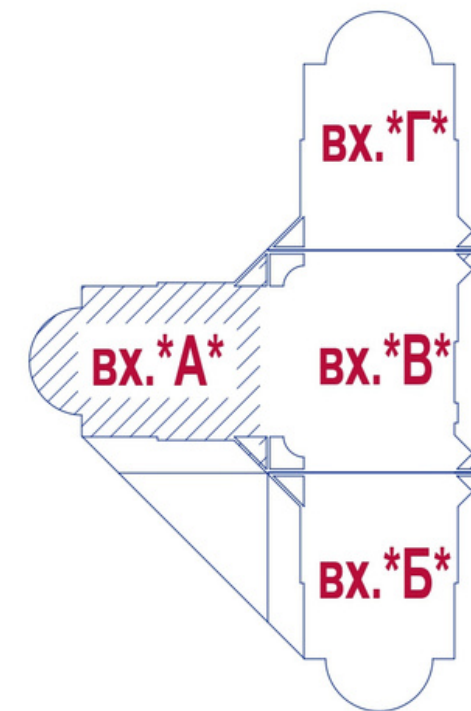
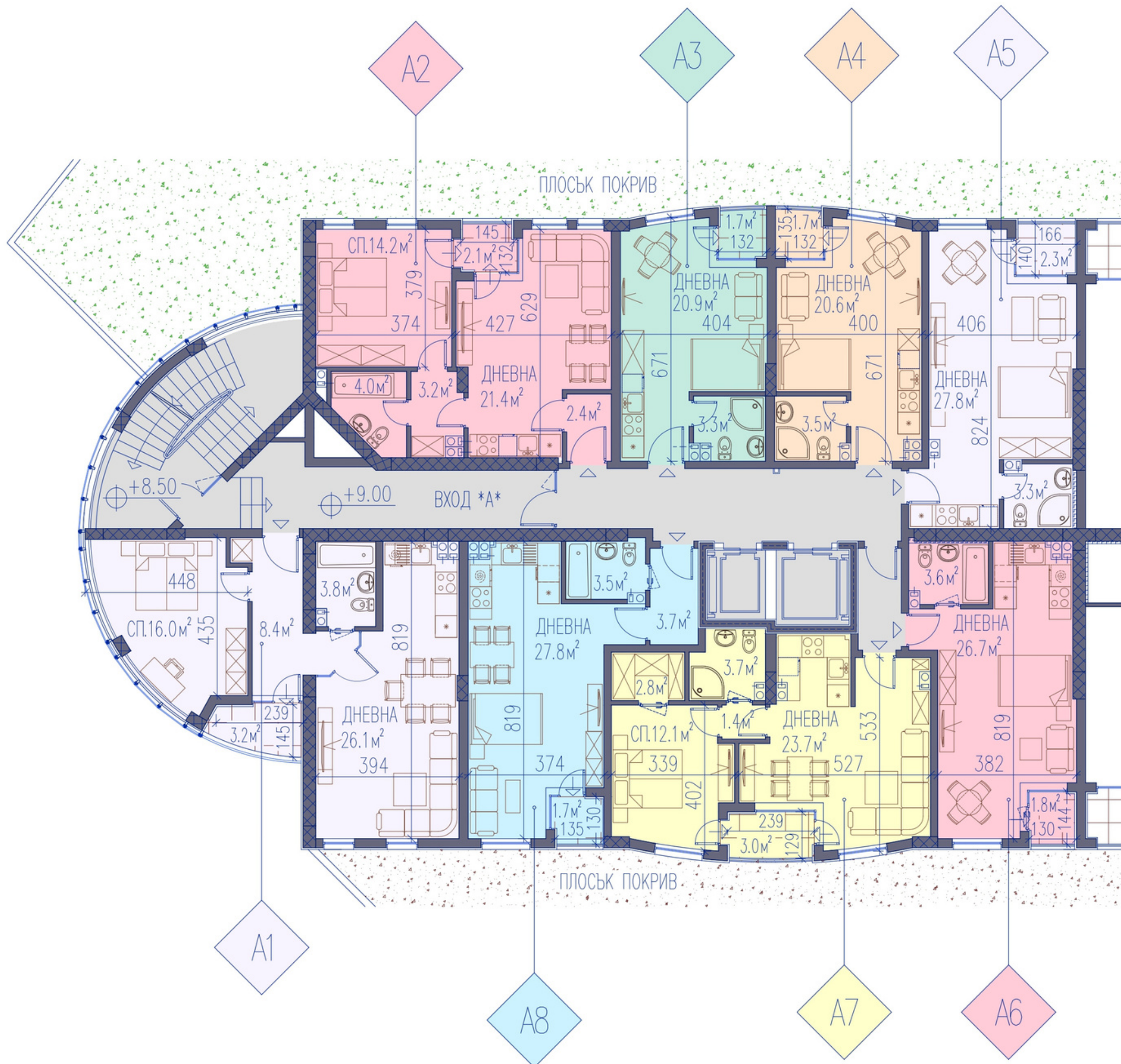

- Ап. А1 - 67,25кв.м /88,10/**
- Ап. А2 - 55,81кв.м /73,06/**
- Ап. А3 - 29,94кв.м /39,72/**
- Ап. А4 - 29,79кв.м /39,53/**
- Ап. А5 - 38,26кв.м /50,15/**
- Ап. А6 - 37,44кв.м /49,03/**
- Ап. А7 - 53,86кв.м /70,10/**
- Ап. А8 - 42,16кв.м /55,40/**

ВХОД *А*
РАЗПРЕДЕЛЕНИЕ ТРЕТИ ЕТАЖ

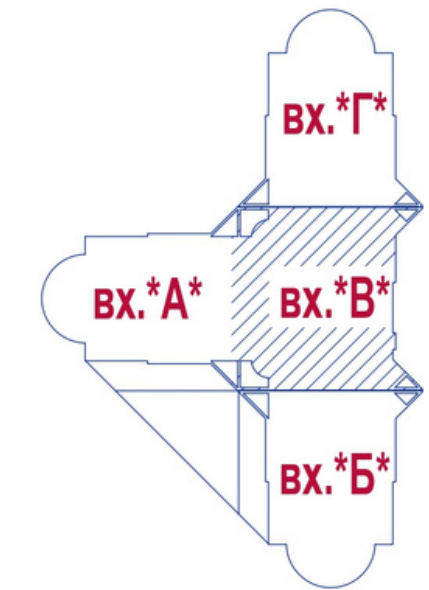
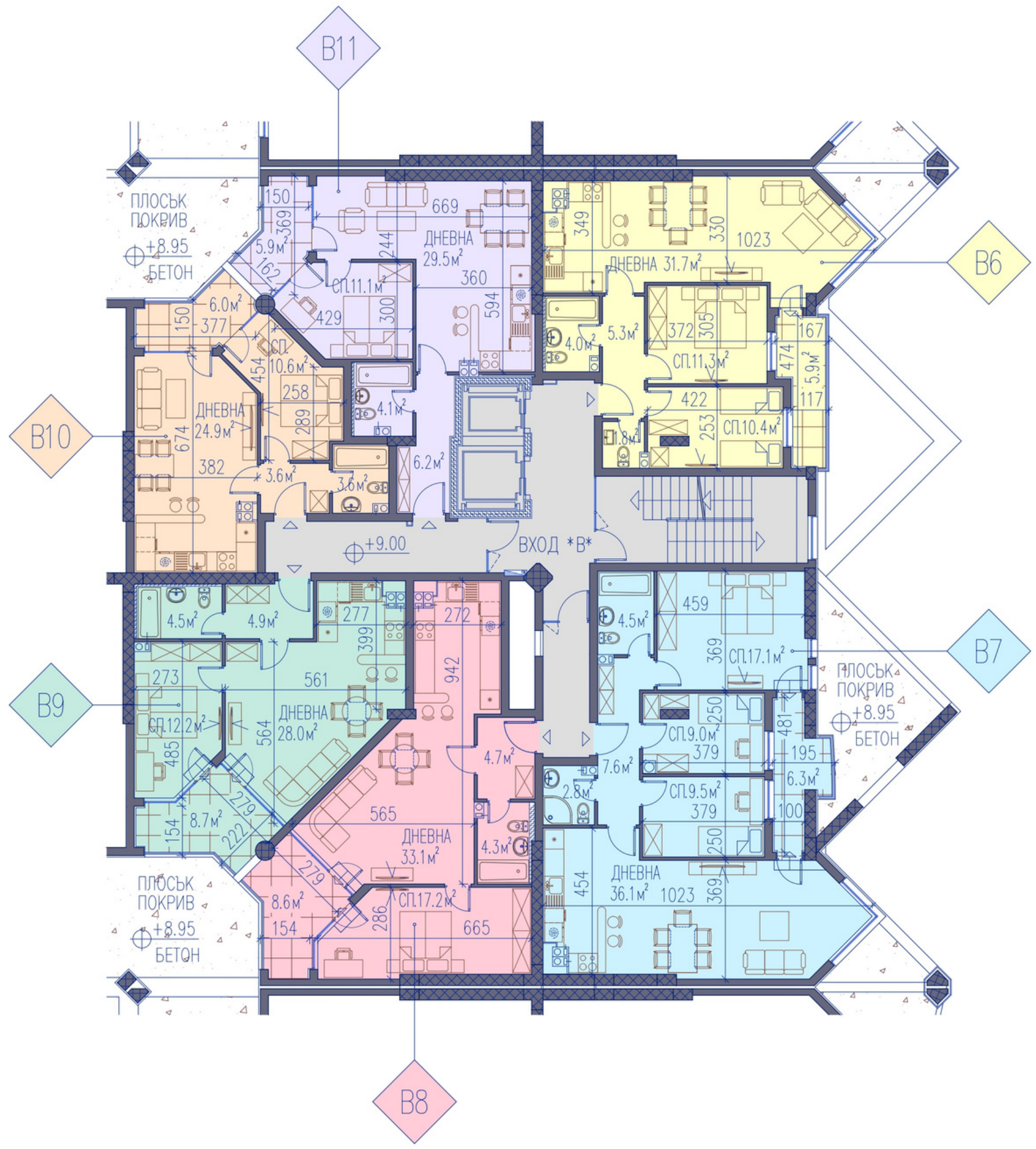

- Ап. В6 - 80,82кв.м /101,37/
- Ап. В7 - 107,43кв.м /134,19/
- Ап. В8 - 75,31кв.м /94,54/
- Ап. В9 - 65,40кв.м /82,26/
- Ап. В10 - 55,30кв.м /69,67/
- Ап. В11 - 64,30кв.м /80,74/

ВХОД *В*
РАЗПРЕДЕЛЕНИЕ ТРЕТИ ЕТАЖ

West Point

ЕТАЖ 4



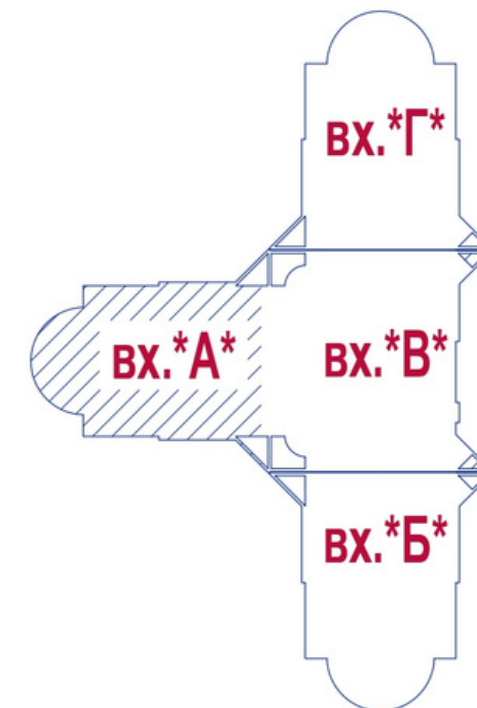
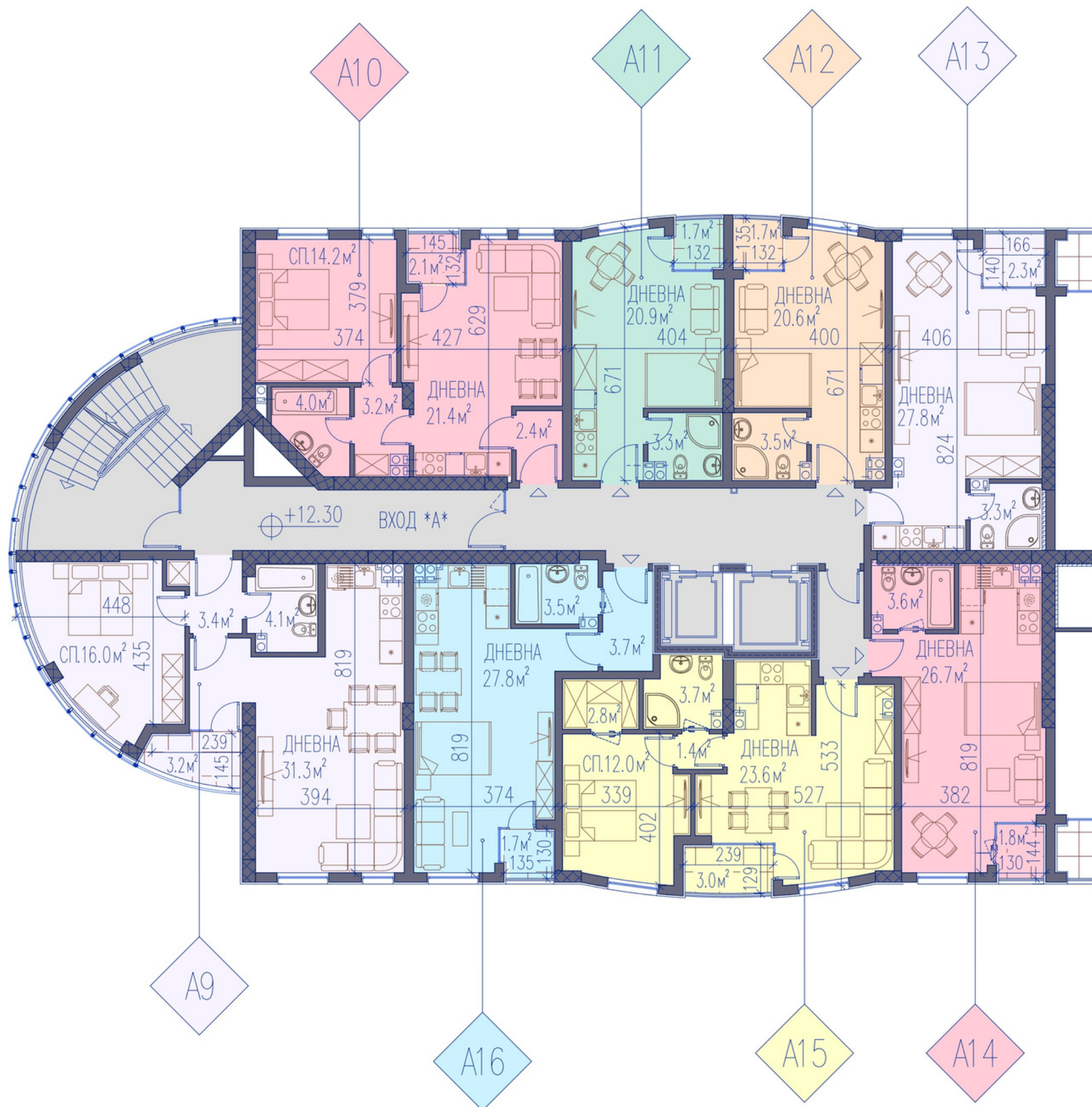

- Ап. А9 - 67,25кв.м /88,05/**
- Ап. А10 - 55,81кв.м /72,93/**
- Ап. А11 - 29,94кв.м /39,72/**
- Ап. А12 - 29,79кв.м /39,53/**
- Ап. А13 - 38,26кв.м /49,94/**
- Ап. А14 - 37,44кв.м /48,91/**
- Ап. А15 - 53,86кв.м /69,55/**
- Ап. А16 - 42,16кв.м /55,34/**

ВХОД *А*
РАЗПРЕДЕЛЕНИЕ ЧЕТВЪРТИ ЕТАЖ

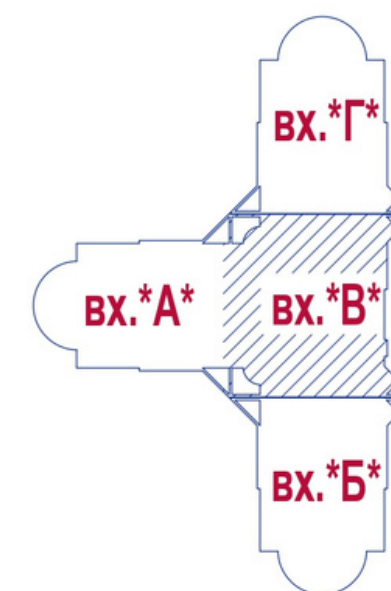
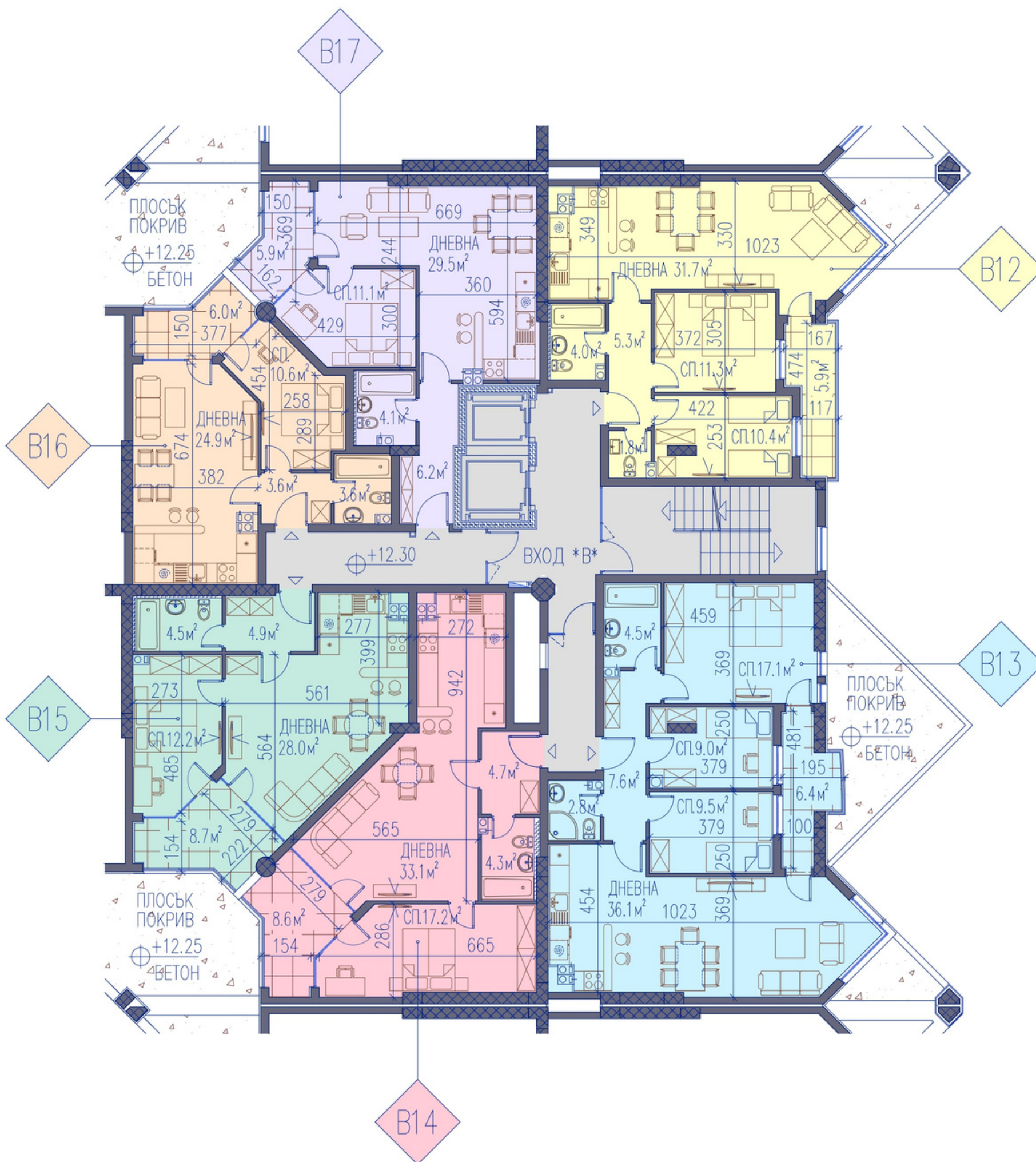

- Ап. В12 - 80,82кв.м /101,33/**
- Ап. В13 - 106,75кв.м /133,32/**
- Ап. В14 - 75,50кв.м /94,74/**
- Ап. В15 - 65,22кв.м /82,04/**
- Ап. В16 - 54,81кв.м /69,07/**
- Ап. В17 - 64,15кв.м /80,56/**

ВХОД *В*
РАЗПРЕДЕЛЕНИЕ ЧЕТВЪРТИ ЕТАЖ



West Point

ETAЖ 5

HAPPY GOLDEN

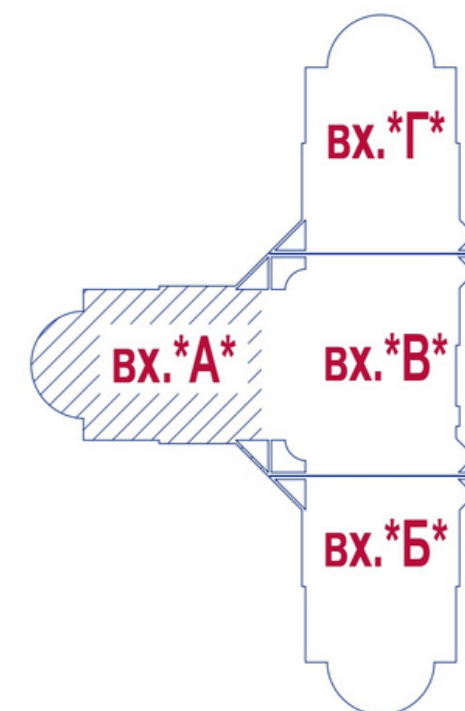
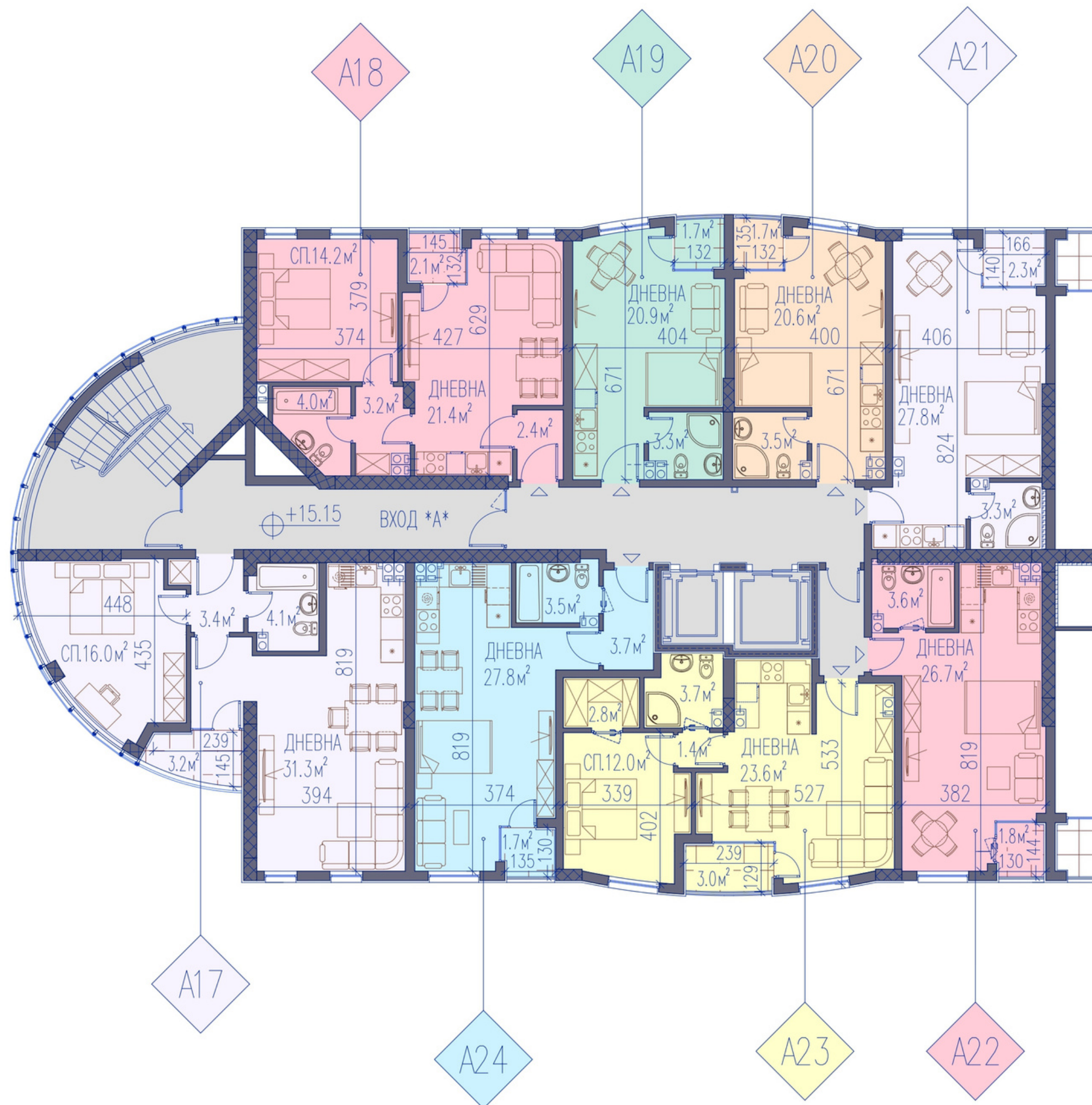

- Ап. А17 - 67,25кв.м /87,89/**
- Ап. А18 - 55,81кв.м /72,91/**
- Ап. А19 - 29,94кв.м /39,72/**
- Ап. А20 - 29,79кв.м /39,53/**
- Ап. А21 - 38,26кв.м /49,91/**
- Ап. А22 - 37,44кв.м /48,91/**
- Ап. А23 - 53,86кв.м /69,99/**
- Ап. А24 - 42,16кв.м /55,31/**

ВХОД *А*
РАЗПРЕДЕЛЕНИЕ ПЕТИ ЕТАЖ

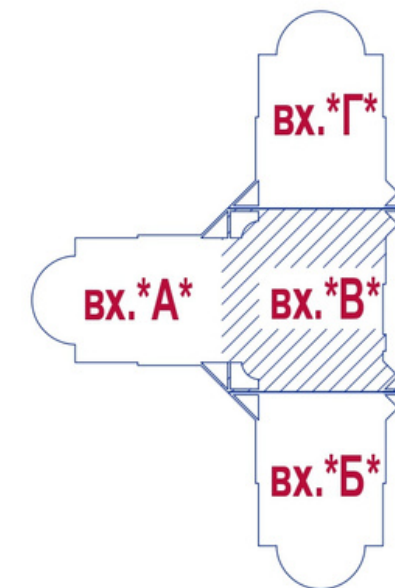

- Ап. В18 - 80,82кв.м /101,33/
- Ап. В19 - 107,53кв.м/134,20/
- Ап. В20 - 76,85кв.м /96,38/
- Ап. В21 - 66,64кв.м /83,66/
- Ап. В22 - 55,64кв.м /70,08/
- Ап. В23 - 65,00кв.м /81,59/

ВХОД *В*
РАЗПРЕДЕЛЕНИЕ ПЕТИ ЕТАЖ

West Point

ЕТАЖ 6



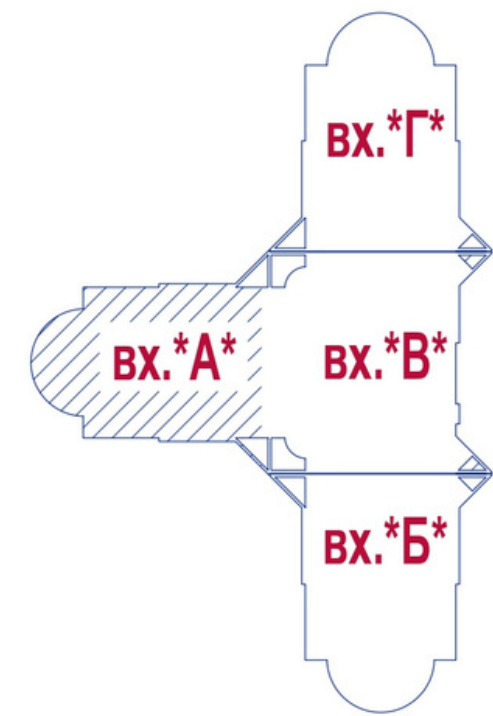
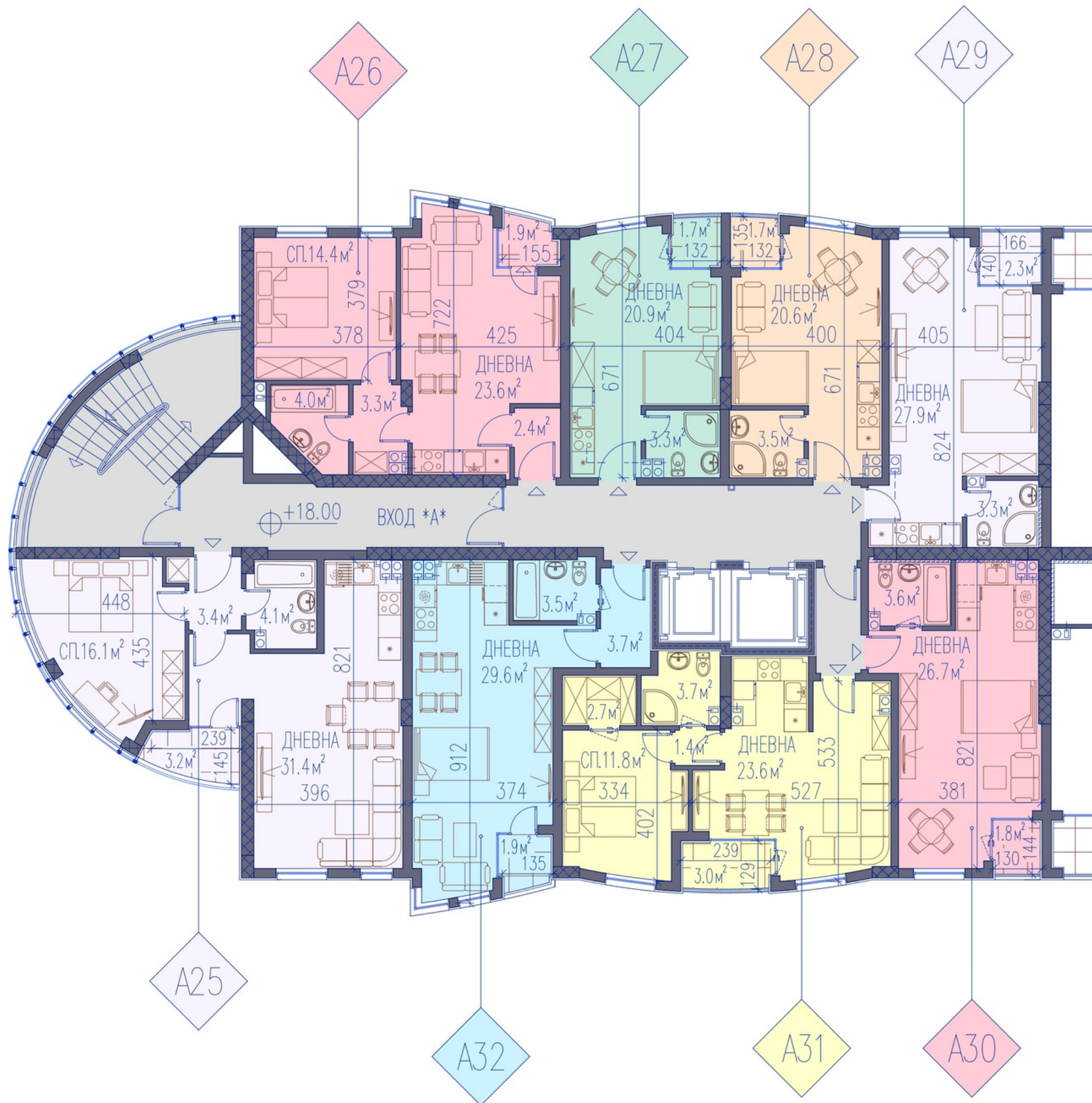

- Ап. А25 - 67,44кв.м /88,10/**
- Ап. А26 - 58,16кв.м /75,73/**
- Ап. А27 - 29,94кв.м /39,72/**
- Ап. А28 - 29,79кв.м /39,53/**
- Ап. А29 - 38,15кв.м /49,77/**
- Ап. А30 - 37,38кв.м /48,82/**
- Ап. А31 - 53,69кв.м /69,76/**
- Ап. А32 - 44,64кв.м /58,32/**

ВХОД *А*
РАЗПРЕДЕЛЕНИЕ ШЕСТИ ЕТАЖ

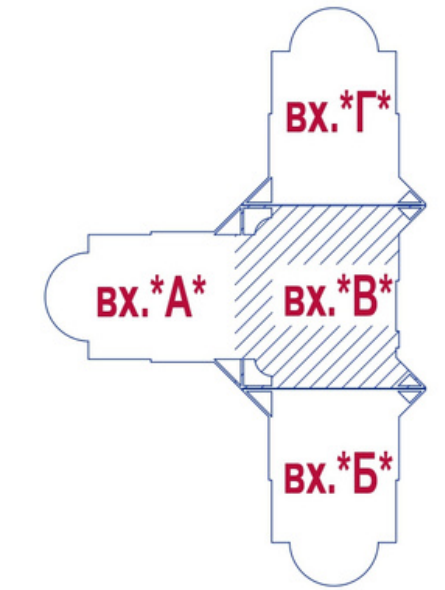

- Ап. В24 - 80,82кв.м /101,32/**
- Ап. В25 - 107,53кв.м/134,13/**
- Ап. В26 - 76,85кв.м /96,36/**
- Ап. В27 - 66,76кв.м /83,73/**
- Ап. В28 - 55,64кв.м /70,08/**
- Ап. В29 - 64,86кв.м /81,42/**

ВХОД *В*
РАЗРЕДЕЛЕНИЕ ШЕСТИ ЕТАЖ



ETAЖК 7

West Point

HAPPY

GOLDEN

WEDNESDAY

THURSDAY

FRIDAY

SATURDAY

SUNDAY

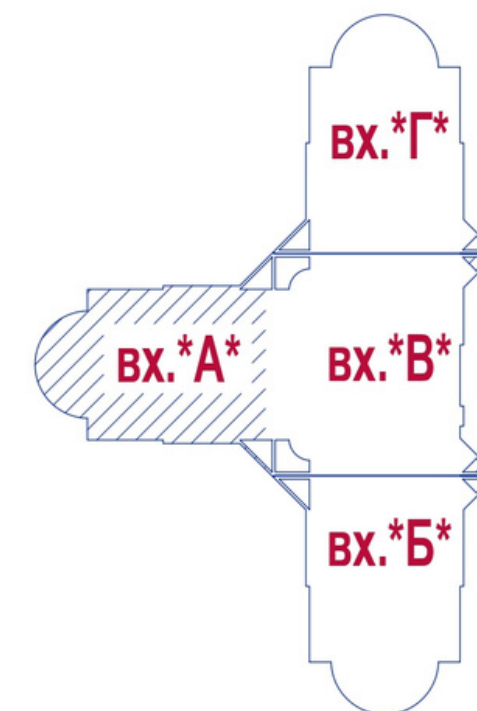
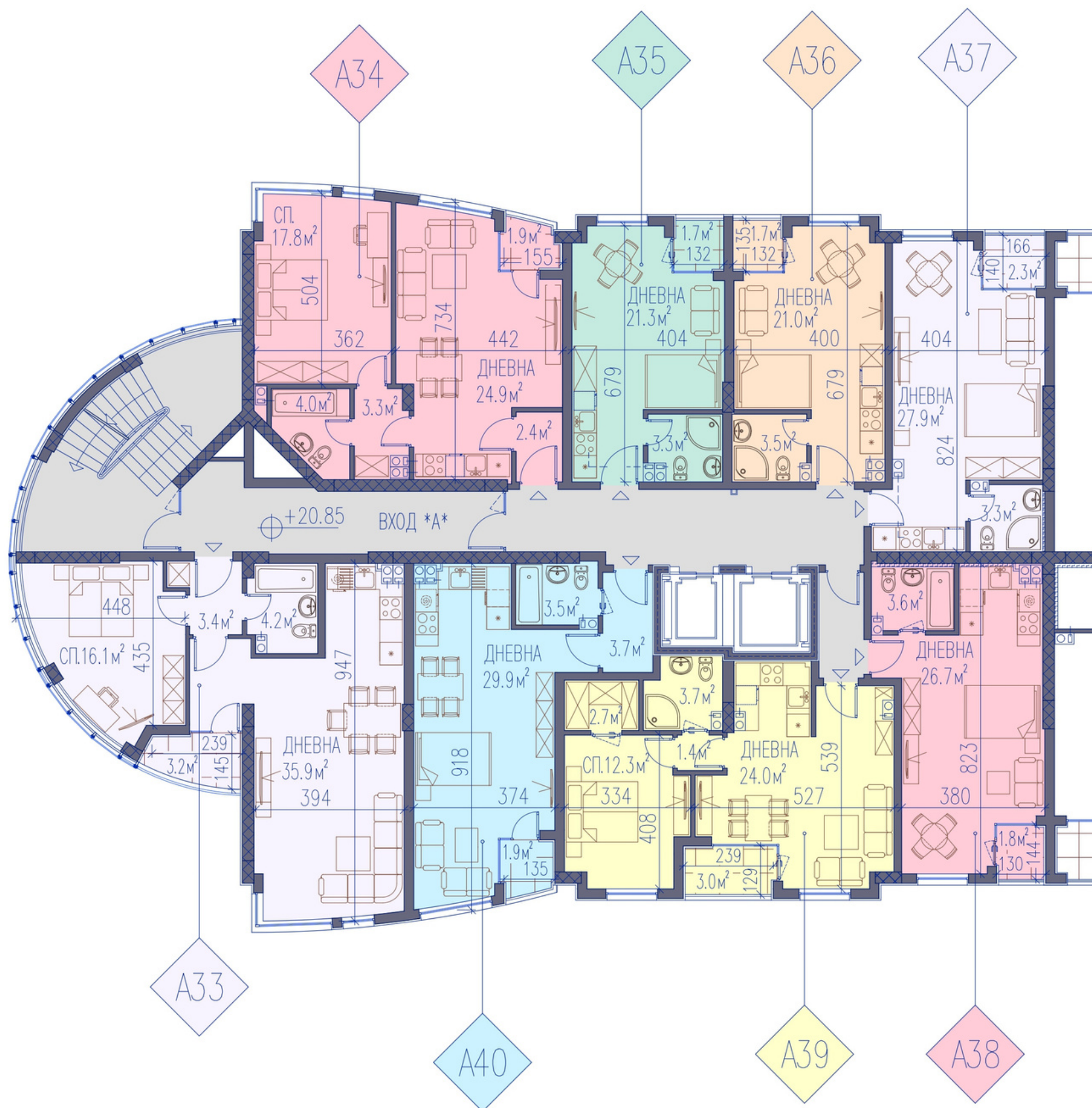

- Ап. А33 - 72,44кв.м /94,08/**
- Ап. А34 - 63,30кв.м /81,97/**
- Ап. А35 - 30,57кв.м /40,48/**
- Ап. А36 - 30,42кв.м /40,30/**
- Ап. А37 - 38,10кв.м /49,66/**
- Ап. А38 - 37,43кв.м /48,81/**
- Ап. А39 - 54,96кв.м /71,26/**
- Ап. А40 - 44,82кв.м /58,53/**

ВХОД *А*
РАЗПРЕДЕЛЕНИЕ СЕДМИ ЕТАЖ

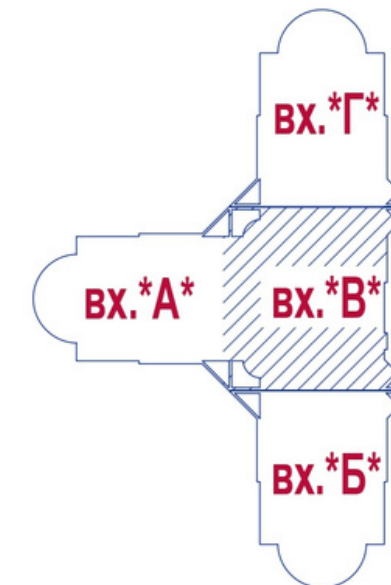
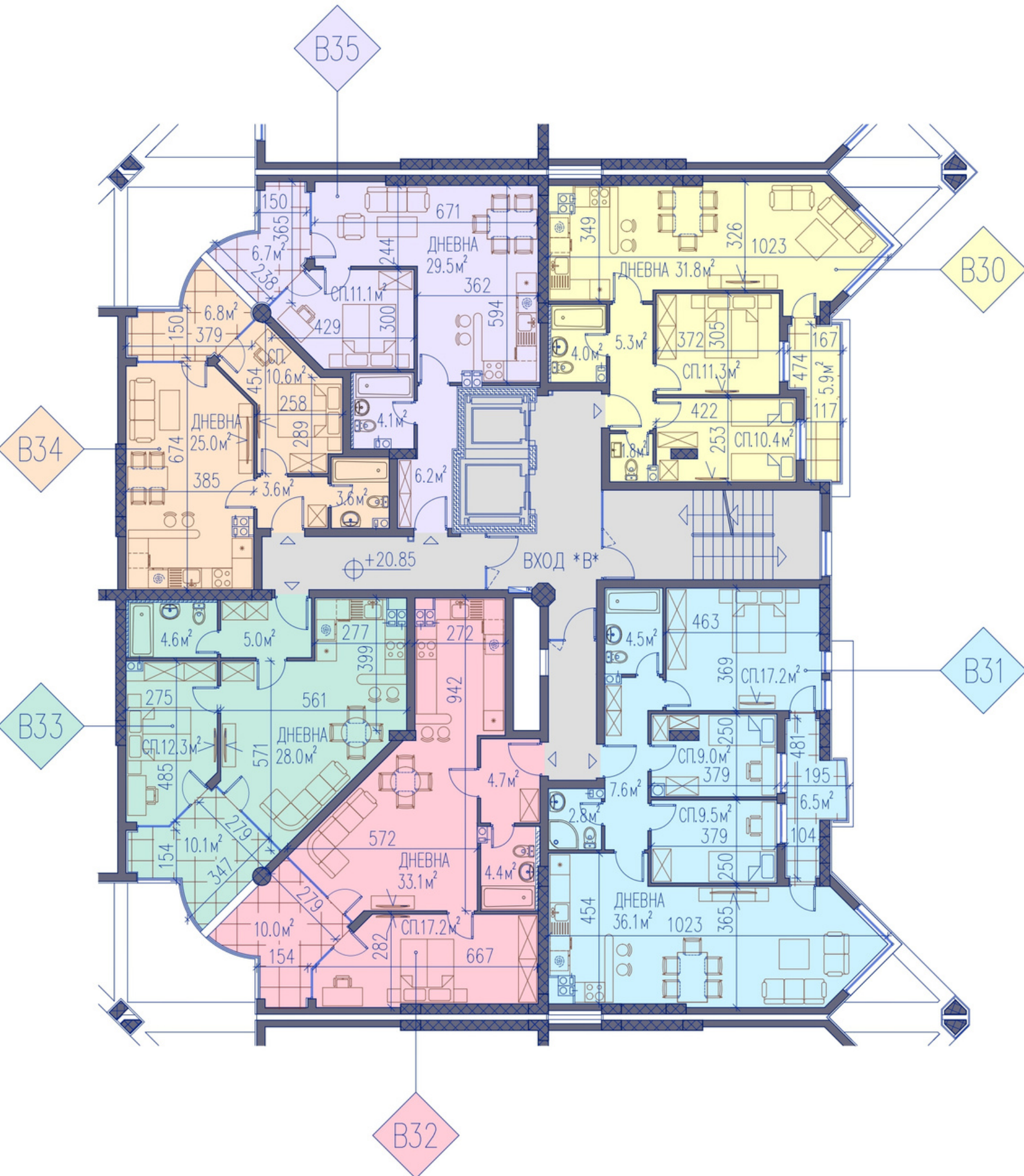

- Ап. В30 - 80,64кв.м /101,04/**
- Ап. В31 - 107,53кв.м /134,13/**
- Ап. В32 - 76,62кв.м /96,06/**
- Ап. В33 - 66,76кв.м /83,73/**
- Ап. В34 - 55,69кв.м /70,14/**
- Ап. В35 - 64,86кв.м /81,42/**

ВХОД *В*
РАЗПРЕДЕЛЕНИЕ СЕДМИ ЕТАЖ

West Point

ЕТАЖ 8



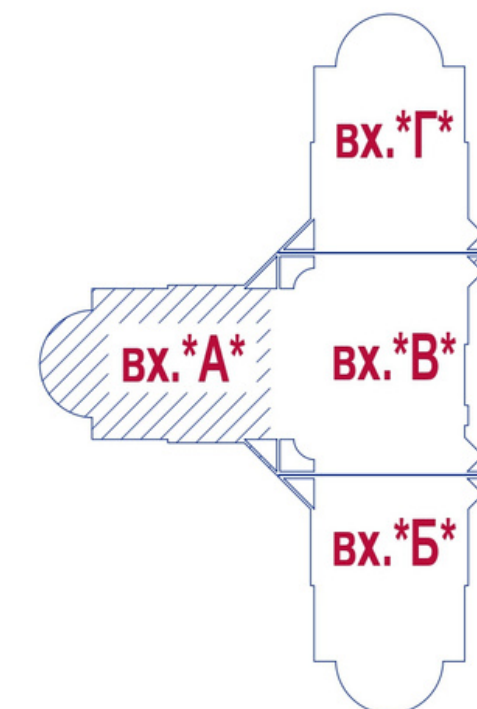
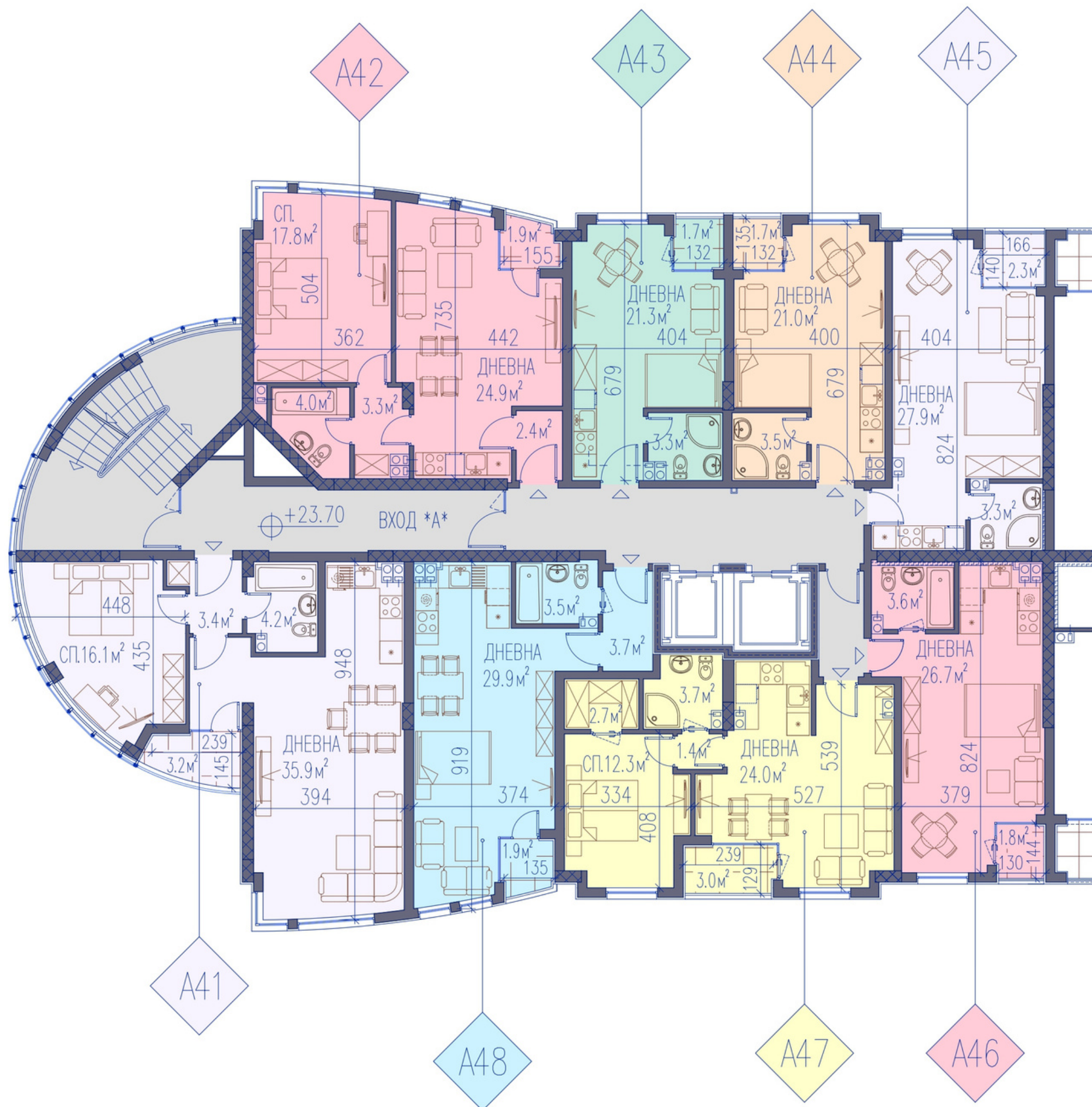

- Ап. А41 - 72,44кв.м /93,89/**
- Ап. А42 - 63,30кв.м /81,96/**
- Ап. А43 - 30,57кв.м /40,44/**
- Ап. А44 - 30,42кв.м /40,20/**
- Ап. А45 - 38,03кв.м /49,54/**
- Ап. А46 - 37,43кв.м /48,81/**
- Ап. А47 - 54,92кв.м /71,12/**
- Ап. А48 - 44,82кв.м /58,34/**

ВХОД *А*
РАЗПРЕДЕЛЕНИЕ ОСМИ ЕТАЖ

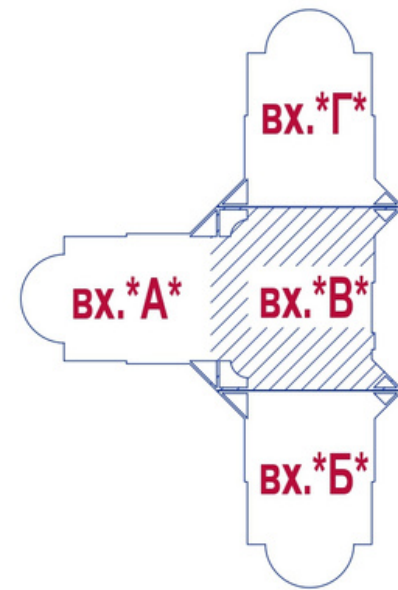
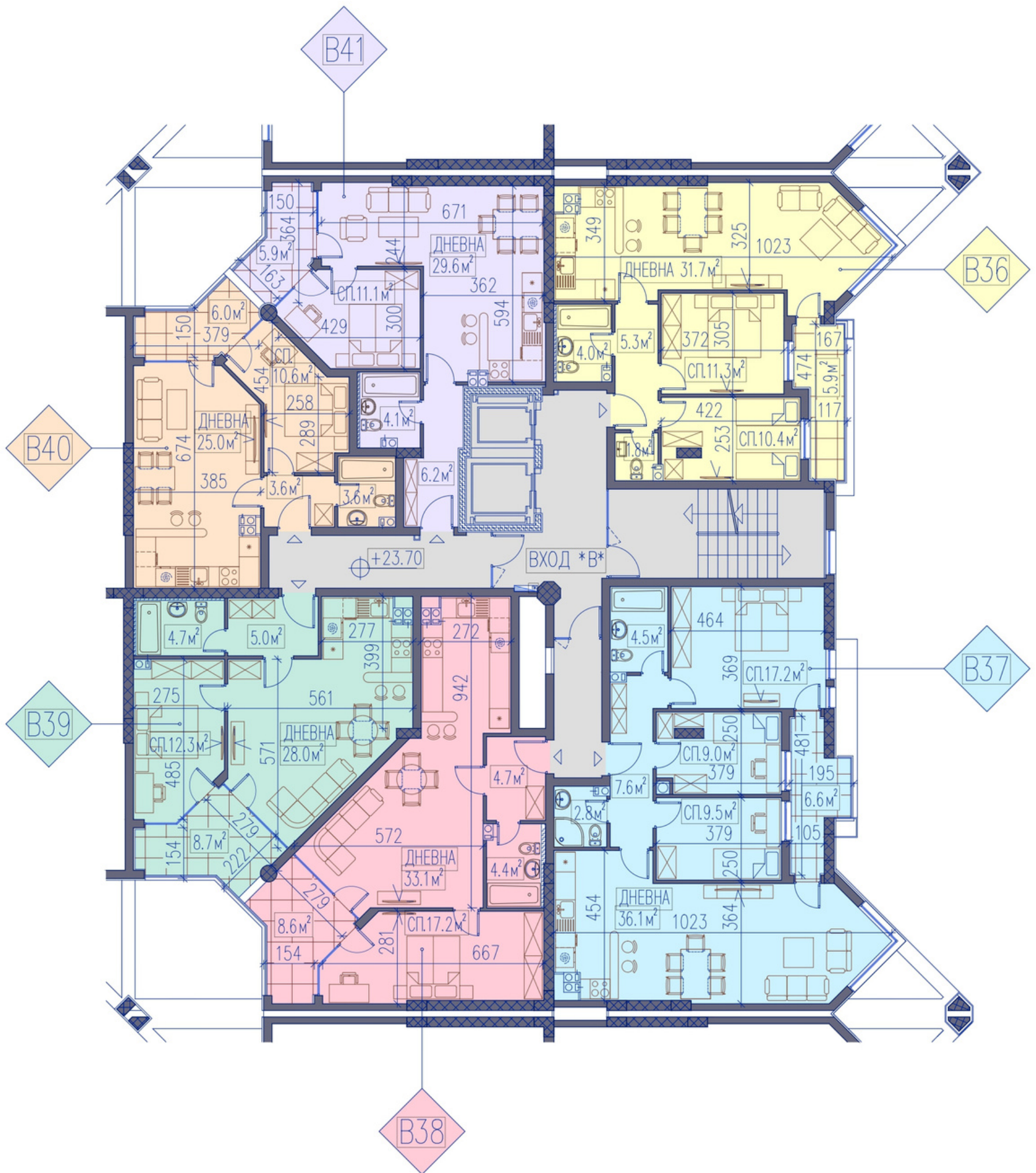

- Ап. В36 - 80,71кв.м /101,10/
- Ап. В37 - 106,40кв.м /132,61/
- Ап. В38 - 75,13кв.м /94,25/
- Ап. В39 - 65,41кв.м /82,09/
- Ап. В40 - 54,85кв.м /69,08/
- Ап. В41 - 64,03кв.м /80,41/

ВХОД *В*
РАЗПРЕДЕЛЕНИЕ ОСМИ ЕТАЖ

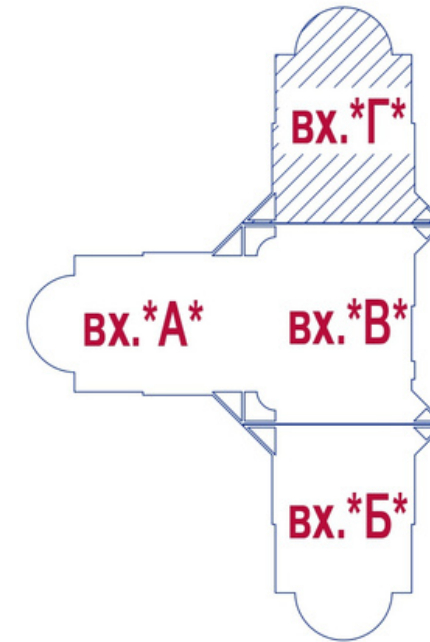
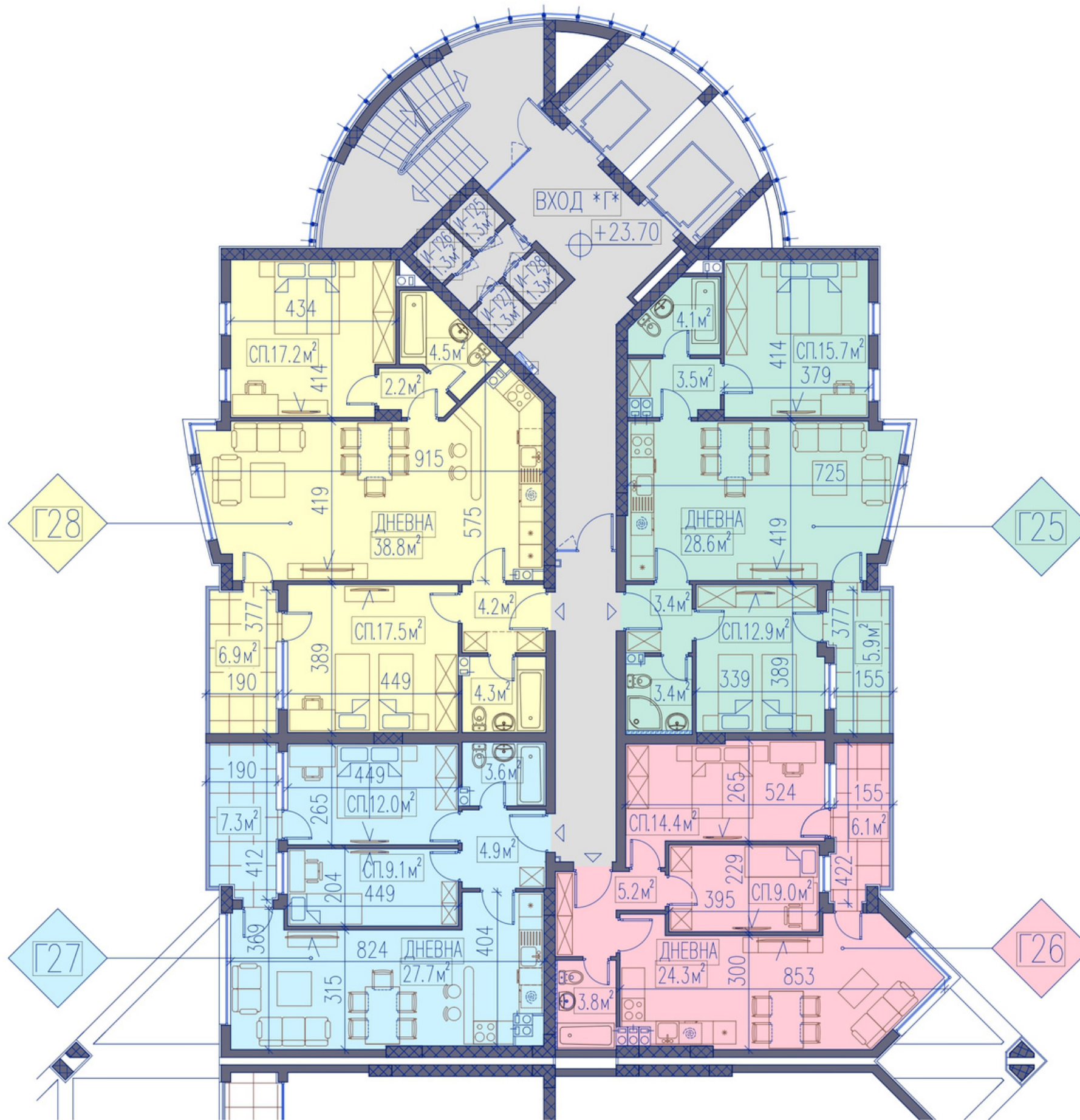

- Ап. Г25 - 88,77кв.м /109,60/**
- Ап. Г26 - 71,43кв.м /88,40/**
- Ап. Г27 - 73,31кв.м /90,86/**
- Ап. Г28 - 107,51кв.м /132,29/**

ВХОД *Г*
РАЗПРЕДЕЛЕНИЕ ОСМИ ЕТАЖ



ETAЖ 9

West Point

HAPPY GOLDEN

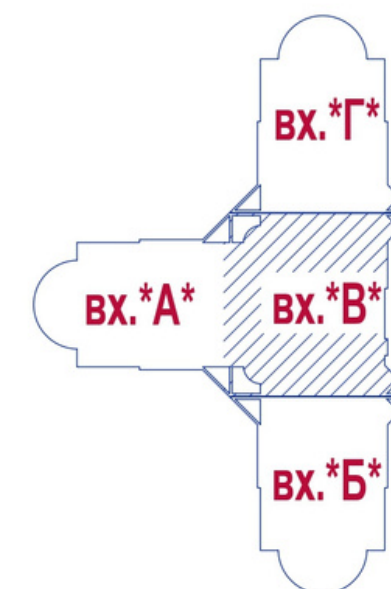
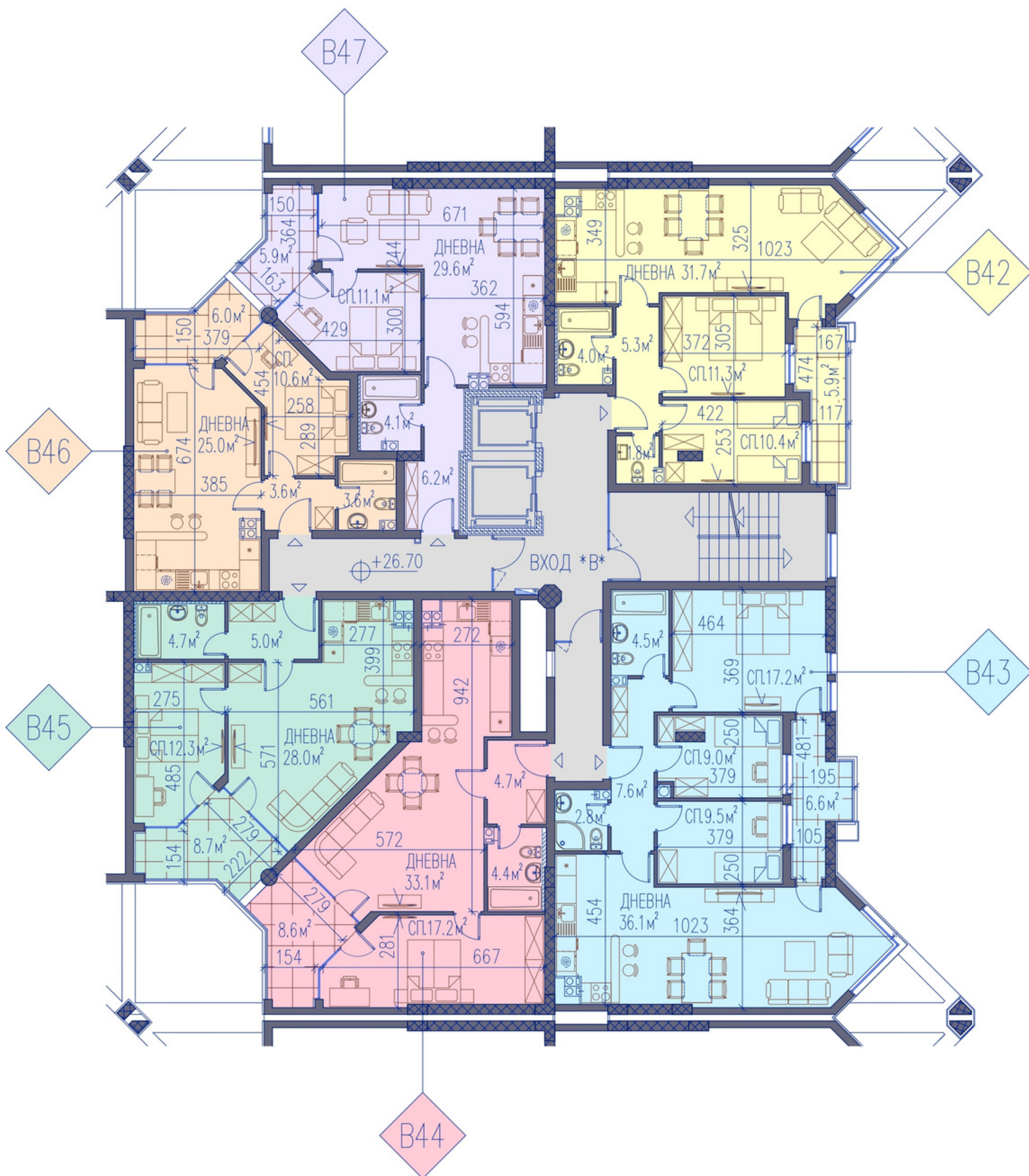

- Ап. В42 - 80,71кв.м /101,10/**
- Ап. В43 - 106,40кв.м /132,53/**
- Ап. В44 - 75,13кв.м /94,22/**
- Ап. В45 - 65,41кв.м /82,09/**
- Ап. В46 - 54,86кв.м /69,04/**
- Ап. В47 - 64,03кв.м /80,30/**

ВХОД *В*
РАЗПРЕДЕЛЕНИЕ ДЕВЕТИ ЕТАЖ



West Point

ЕТАЖ 10

HAPPY GOLDEN



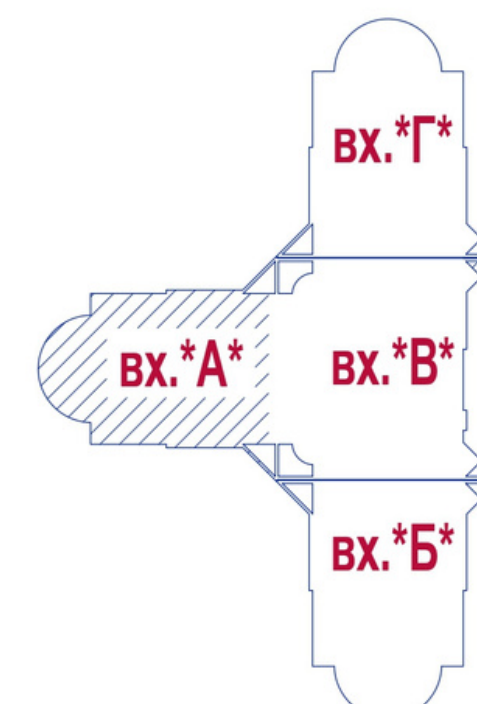
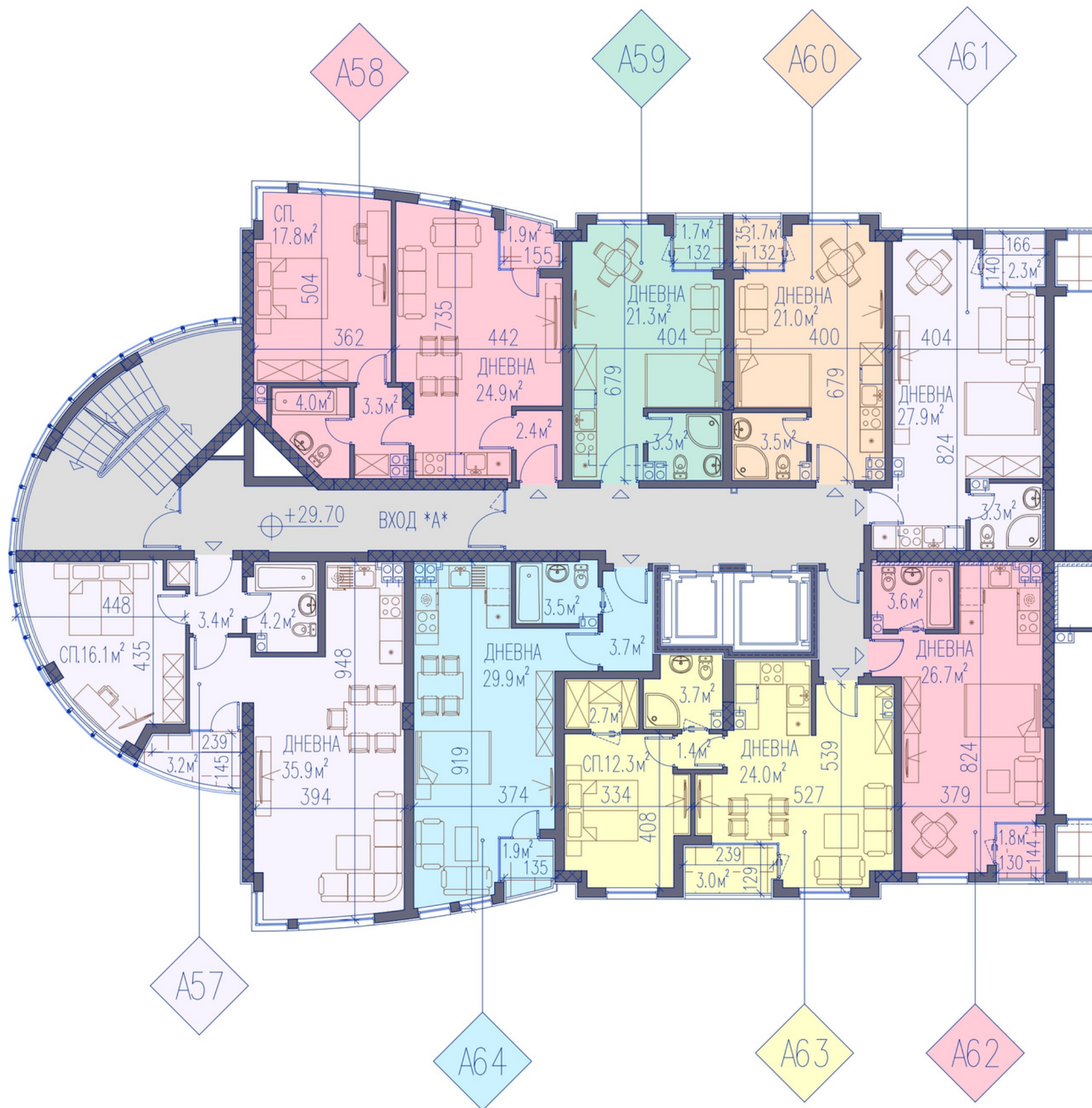

- Ап. А57 - 72,44кв.м /93,73/**
- Ап. А58 - 63,30кв.м /81,79/**
- Ап. А59 - 30,57кв.м /40,14/**
- Ап. А60 - 30,42кв.м /39,94/**
- Ап. А61 - 38,03кв.м /49,54/**
- Ап. А62 - 37,43кв.м /48,81/**
- Ап. А63 - 54,92кв.м /71,00/**
- Ап. А64 - 44,82кв.м /58,29/**

ВХОД *А*
РАЗПРЕДЕЛЕНИЕ ДЕСЕТИ ЕТАЖ

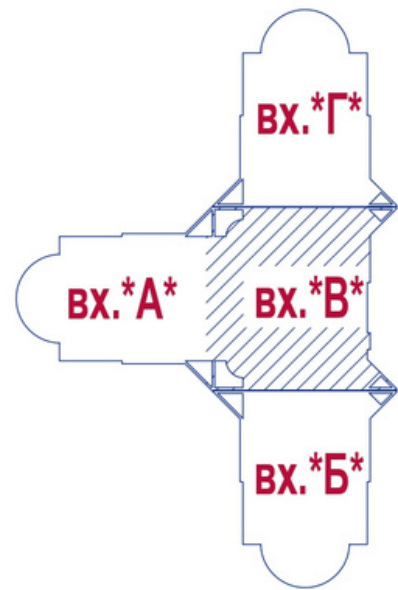

- Ап. В48 - 80,71кв.м /101,10/**
- Ап. В49 - 106,40кв.м /132,51/**
- Ап. В50 - 75,13кв.м /94,18/**
- Ап. В51 - 65,41кв.м /82,09/**
- Ап. В52 - 54,85кв.м /69,01/**
- Ап. В53 - 64,03кв.м /80,30/**

ВХОД *В*
РАЗПРЕДЕЛЕНИЕ ДЕСЕТИ ЕТАЖ



West Point

ETAЖ 11

HAPPY GOLDEN

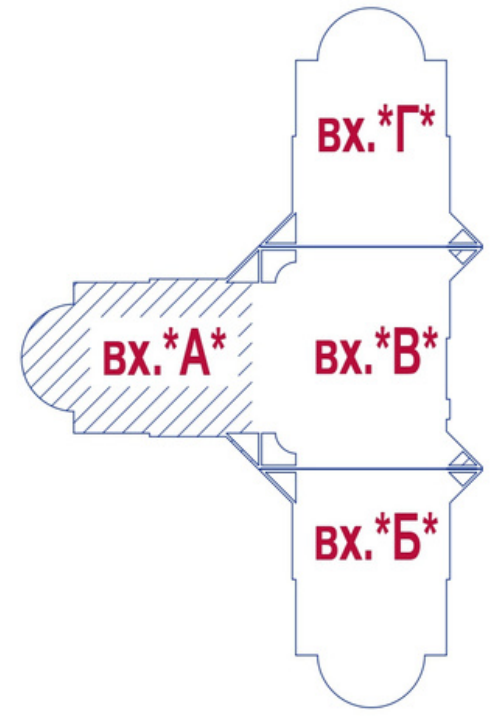

- Ап. А65 - 72,44кв.м /93,70/**
- Ап. А66 - 63,30кв.м /81,77/**
- Ап. А67 - 30,57кв.м /40,01/**
- Ап. А68 - 30,42кв.м /39,79/**
- Ап. А69 - 38,03кв.м /49,54/**
- Ап. А70 - 37,43кв.м /48,81/**
- Ап. А71 - 54,92кв.м /70,90/**
- Ап. А72 - 44,82кв.м /58,29/**

ВХОД *А*
РАЗПРЕДЕЛЕНИЕ ЕДИНАДЕСЕТИ ЕТАЖ

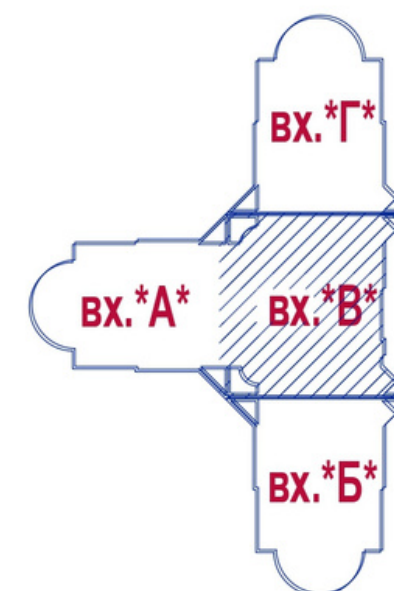

- Ап. В54 - 80,71кв.м /101,10/**
- Ап. В55 - 106,40кв.м /132,49/**
- Ап. В56 - 75,13кв.м /94,18/**
- Ап. В57 - 65,41кв.м /82,09/**
- Ап. В58 - 54,85кв.м /69,01/**
- Ап. В59 - 64,03кв.м /80,30/**

ВХОД *В*
РАЗПРЕДЕЛЕНИЕ ЕДИНАДЕСЕТИ ЕТАЖ



Кристина Шупак

Свържете се с мен за повече информация



+359 879 036 865



kshupak@buildingbox.bg