

■ Basic

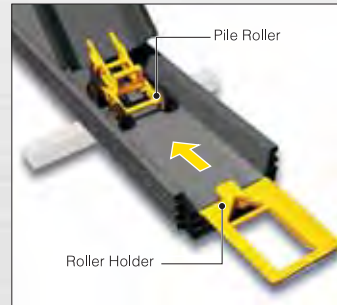

Pile Roller

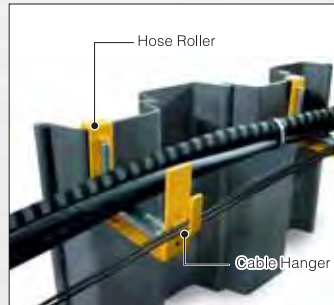

Hose Roller



Pile Laser



Module Box



Tablet PC (encased)

■ Optional



Piler Jet Reel (JR28)



Piler Stage for Standard Mode

■ Super Crush Mode



Piler Stage for Super Crush Mode



Auger Head



Auger Head Replacement Attachment

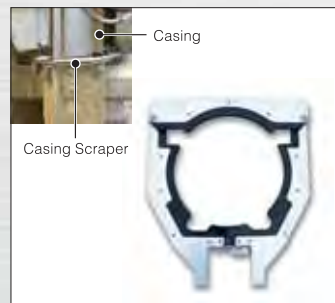

Casing Scraper



Construction Solutions Company

www.giken.com

CONTACT US



"SILENT PILER" is a registered trademark or trademark of GIKEN LTD. in the United States and other countries.

© 2015 GIKEN LTD. All Rights Reserved.

T4_Ver 2.0ENus03 / 22 Sep 2021



SILENT PILER™
F111
 for U Sheet Piles
 15.74 in wide



Highly versatile modular model applicable to U Sheet Piles (15.74 in wide)

SILENT PILER™ F111

SILENT PILER F111

Flexible and Functional Formula

The F111 features a new modular design developed by optimizing all its parts while drastically modifying its structure, shape, and material.

Not only are main component parts more versatile; the F111 is also equipped with a cutting-edge control system that recognizes high functionality with a longer operation life.



1 Optimizing Work Efficiency with Modular Design

The SILENT PILER F111 is applicable to Standard, Water Jetting, and Super Crush press-in work by changing the chuck, chuck frame, and adaptable attachments. The machine can be utilized more efficiently since it adapts to various soil conditions and working conditions.

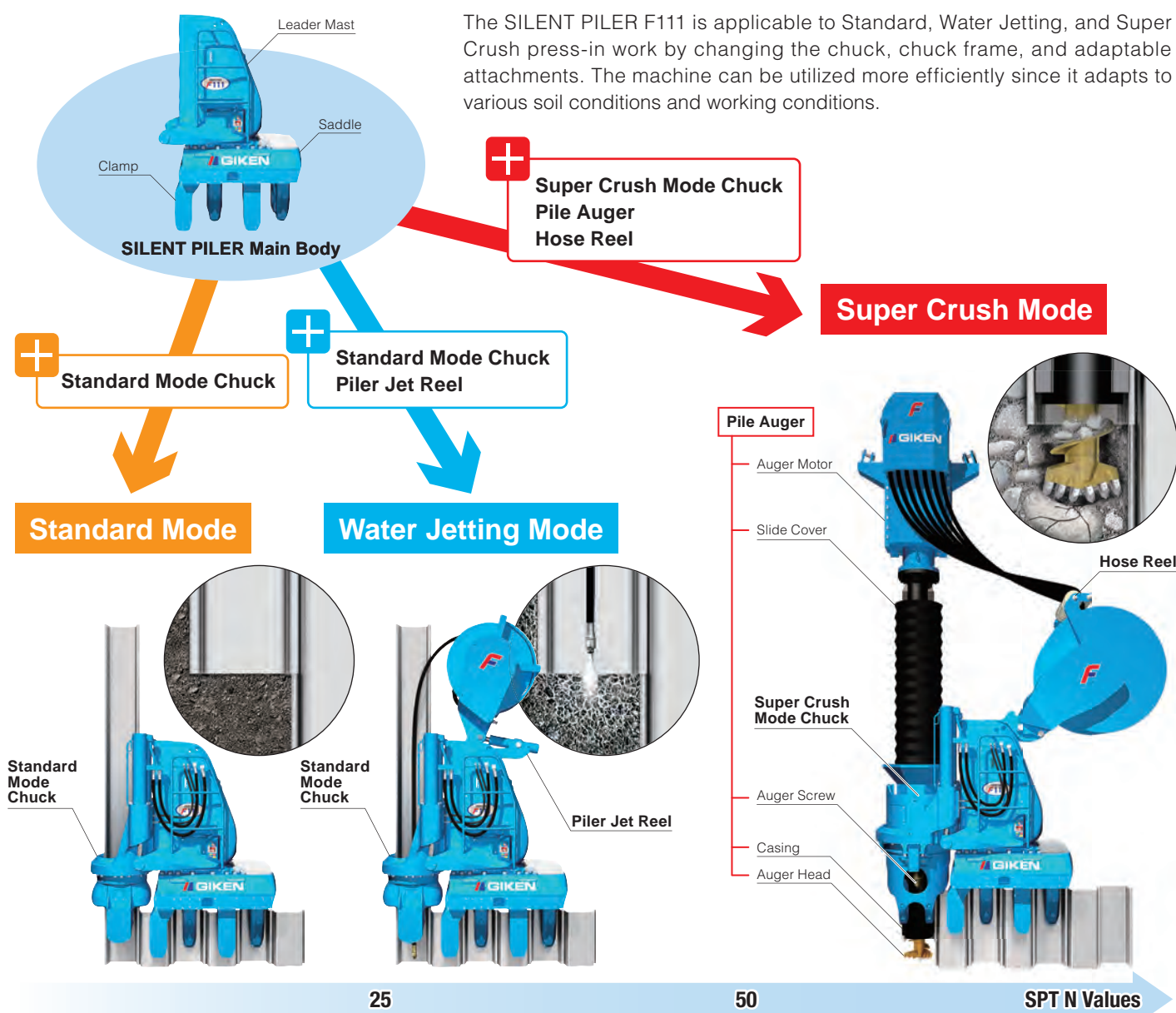

2 Features of SILENT PILER F Series (New Standards of Press-in Machine)

● New Control System

The new control system manages the position of the press-in machine and controls load generation from press-in work during operation; maximizing the durability of each part. Also, control of the machine is remarkably improved by the Press-in Force Control System and the Phaseless Linear Auger Torque Control System.

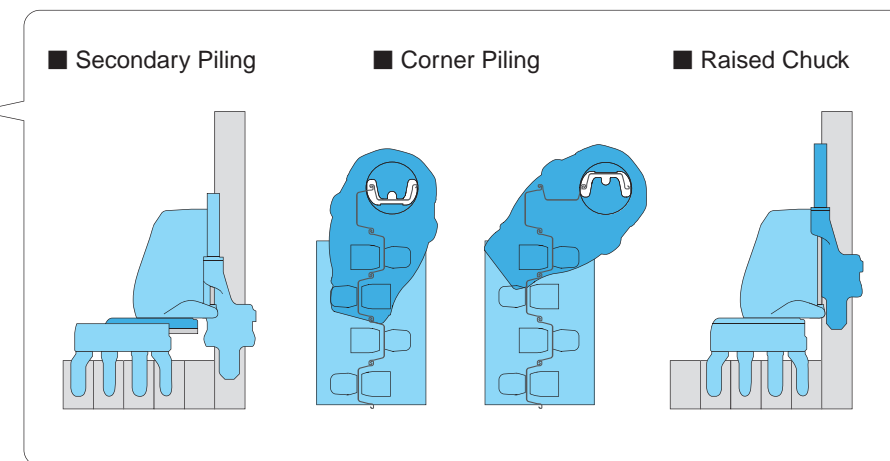
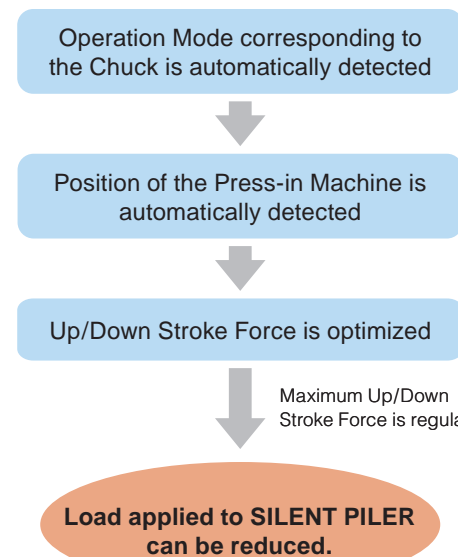

● Increased Machine Rigidity and Guiding Precision

For the SILENT PILER F Series, the durability of its components along with the accuracy of its guiding precision are increased compared to previous models to achieve higher machine performance. Also, assembly tolerances in guiding systems are minimized by implementing longer slide rails and greater sliding surfaces to increase machine life.

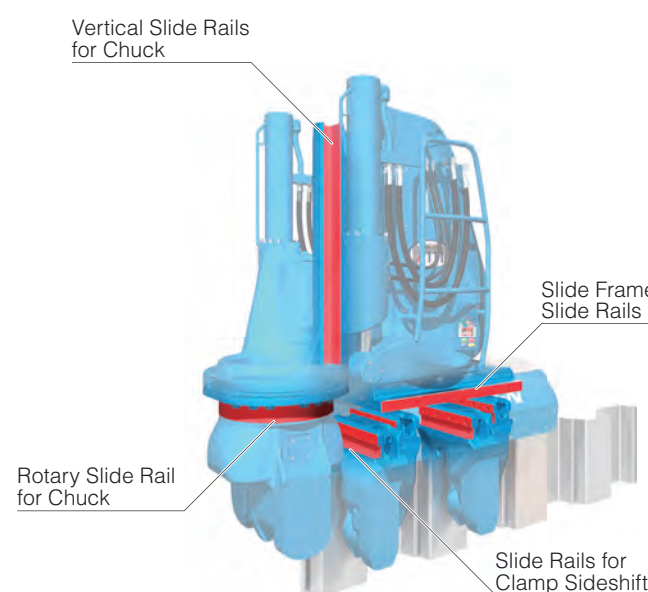

● Addition of Abrasion Resistant Plates

Detachable abrasion resistant plates have been added along the vertical slide rails for the Chuck which provide 3.6 times the wear resistance compared to previous models. Hence, high guiding precision is achieved while maintenance costs are reduced.



● Tablet PC

Real-time information of piling operations can be displayed on a tablet PC which can be attached to the side of the SILENT PILER.



- Displays piling monitoring data
- Displays comparison of the current data to the previous monitoring results
- Displays the machine settings and status during piling work
- Displays borehole log
- Displays Operation Manual & Parts List

3 Pile Installation into Hard Ground

The "Pilot Coring Theory", GIKEN original theory, allows the Hard Ground Press-in Method to install sheet piles into difficult ground conditions such as gravelly soil and soil mixed with cobbles and boulders without losing the advantages of the Press-in Method. Previous Crush Piler models have proven the superiorities of the Hard Ground Press-in Method in the field.

The augering area can be reduced to assist pile installation; minimizing the volume of spoil and disturbance to the soil strata. Therefore, high bearing capacity is possible with sheet piles that are installed with the Hard Ground Press-in Method. The Hard Ground Press-in Method can install sheet piles even under restricted site conditions such as on slopes or water where conventional piling techniques would be ineffective. By adopting the GRB System, temporary work platforms are no longer necessary, dramatically reducing the environmental burden.

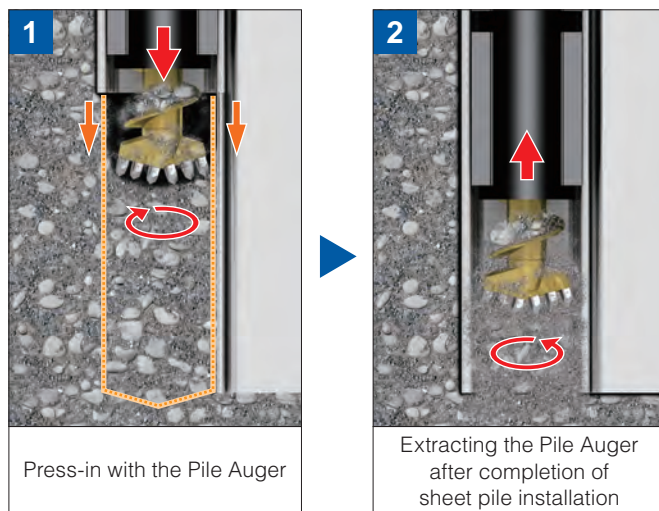

NEW 1 Locking Function

Lock functions in the chuck, leader mast, and clamps secure SILENT PILER against drilling torque and increase drilling efficiency and accuracy of pile installation.

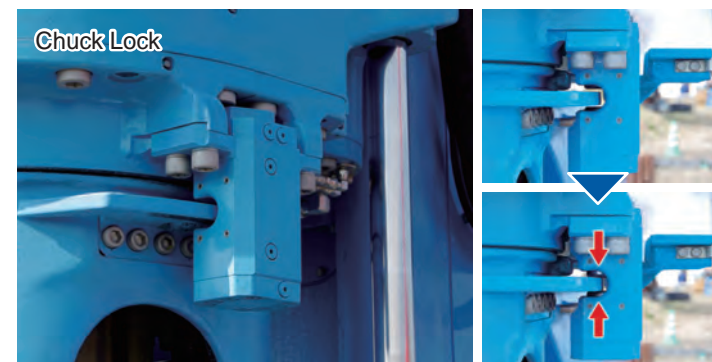

NEW 2 Improved Design of Auger Head and Teeth

Female socket teeth can minimize wear on tooth mounts and maximize drilling efficiency with minimal assembly tolerance. Also, pilot teeth and outer teeth are standardized.

A 12-point double hexagon joint of the auger shaft and auger head achieves a higher torque application and reduces weight. The joint is locked with only one stopper pin instead of two for easier assembly and securely locked with a C-shaped stopper ring.

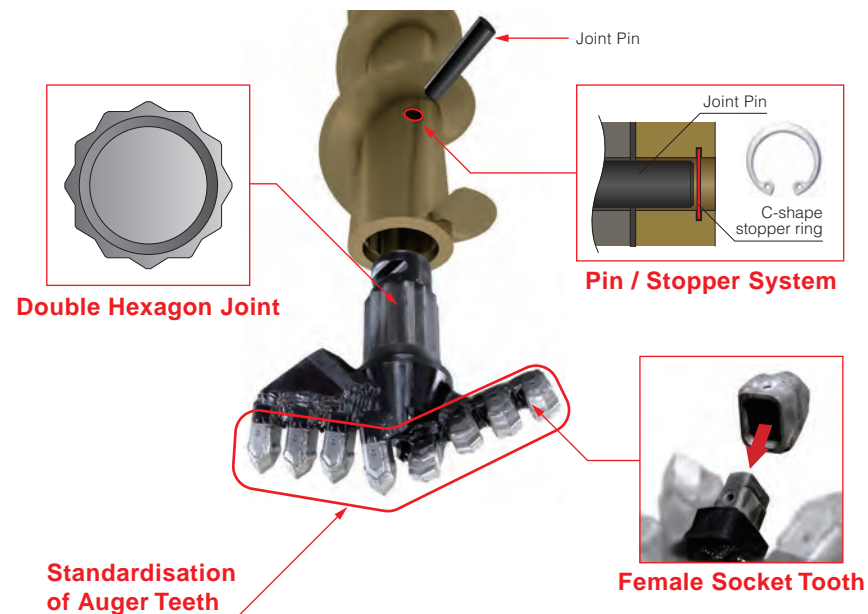

NEW 3 Improved Auger Screw & Casing

The improved auger screw and auger casing provide higher torque application and center drilling accuracy, which can achieve higher augering efficiency. The durability of the auger screw is also extended by minimizing the tolerance between the auger screw and auger casing; therefore the auger is less likely to wear out.

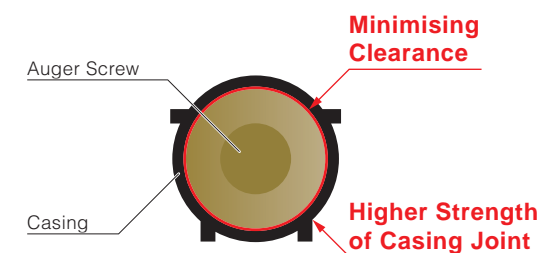

NEW 4 Longer Applicable Pile Length

The maximum applicable sheet pile length for the F111 is 78.74 ft., which is greater than those of the previous models.

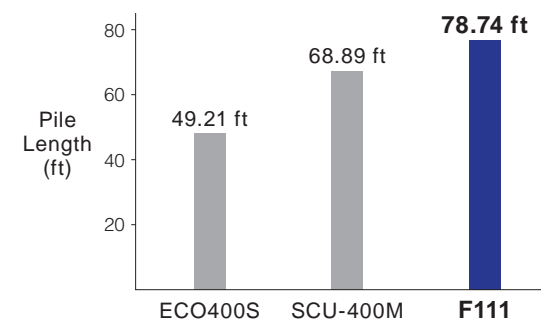

NEW 5 Increased Power Capacity of Auger

The F111 auger motor has 1.4 times higher power capacity than the previous model (ECO400S). This results in the ability to maintain high speed augering even within a greater torque range.

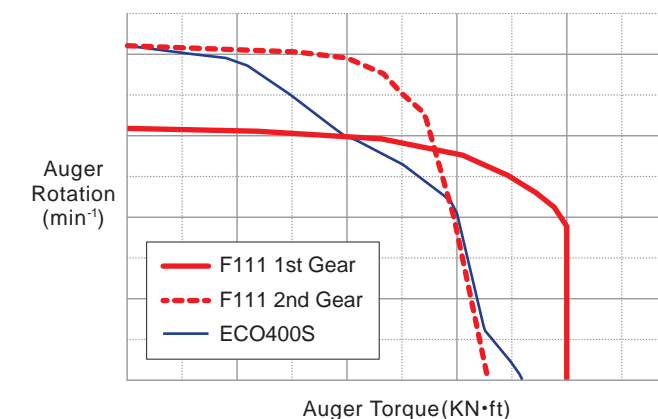

NEW 6 Compact Machine Size

The F111 is 5.90 in. narrower than the previous model (ECO400S) and can be adopted for more confined site conditions.

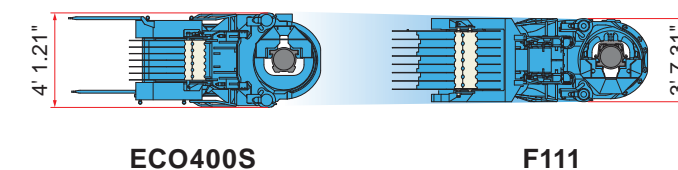

4 High Performance also in Standard Mode

Despite its universal design, the F111 provides a similar high performance as its previous Standard Mode Custom Models.

Model	ECO100-4CA	F111	ECO400S
Operation Mode	Standard Mode (Custom Model)	Standard Mode (Modular Model)	Standard Mode (Custom Model)
Max. Press-in Force	112.4 ton(US)	112.4 ton(US)	89.9 ton(US)
Max. Extraction Force	123.6 ton(US)	123.6 ton(US)	101.1 ton(US)
Press-in Speed	6.23 ~ 115.48 ft/min	6.56 ~ 142.71 ft/min	4.92 ~ 116.46 ft/min
Extraction Speed	5.90 ~ 128.28 ft/min	4.92 ~ 180.44 ft/min	4.92 ~ 165.68 ft/min
Mass (SILENT PILER Main Body)	15542 lb	15542 lb	16314 lb
Mass (Power Unit)	14660 lb	14330 lb	16093 lb
Rated Output	261 HP / 1800 rpm	355 HP / 1800 rpm	261 HP / 1800 rpm

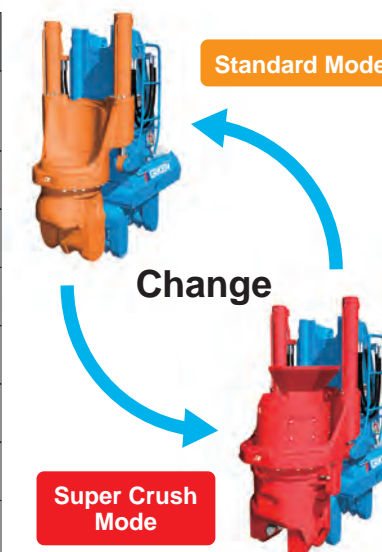

5 New Generation Power Unit EU300K4

Low Emission Engine

The Power Unit for the F111 is a new generation model with environmentally friendly specifications. It is designed with strict concepts for clean emissions with high combustion efficiency and with GIKEN original hydraulic control technologies.



Ultra Low Noise Level

It clears allowable construction noise levels in many industrialized countries.

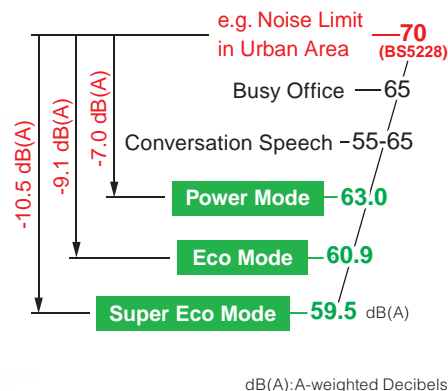

Standard Application of Biodegradable Oil

The F111 uses biodegradable PILER ECO OIL and PILER ECO Grease. Therefore, if hydraulic oil or grease is spilled into soil or water, there will be no environmental damage to the surrounding ecosystem. In addition, the machines are painted with TX-Free non-lead paint*.

* Environmentally friendly paint which does not contain toluene, xylene, and lead based pigment.



6 Scientific Execution of Press-in Work & Advanced IT Functions

GIKEN IT System

GIKEN engineers can monitor individual SILENT PIER operating condition, maintenance records, and location. Quick advice for any technical difficulties is available promptly. Appropriate information can also be provided to prevent additional issues.

* The system is not available in the countries where authorization for usage cannot be acquired.

Press-in Monitoring and Data Logging System

Press-in monitoring data can be used for quality control and for supporting information for foundations. Operators are able to keep working while checking data such as press-in force, auger torque, and working hours of press-in work on a tablet or PC (both devices optional).

GIKEN IT System

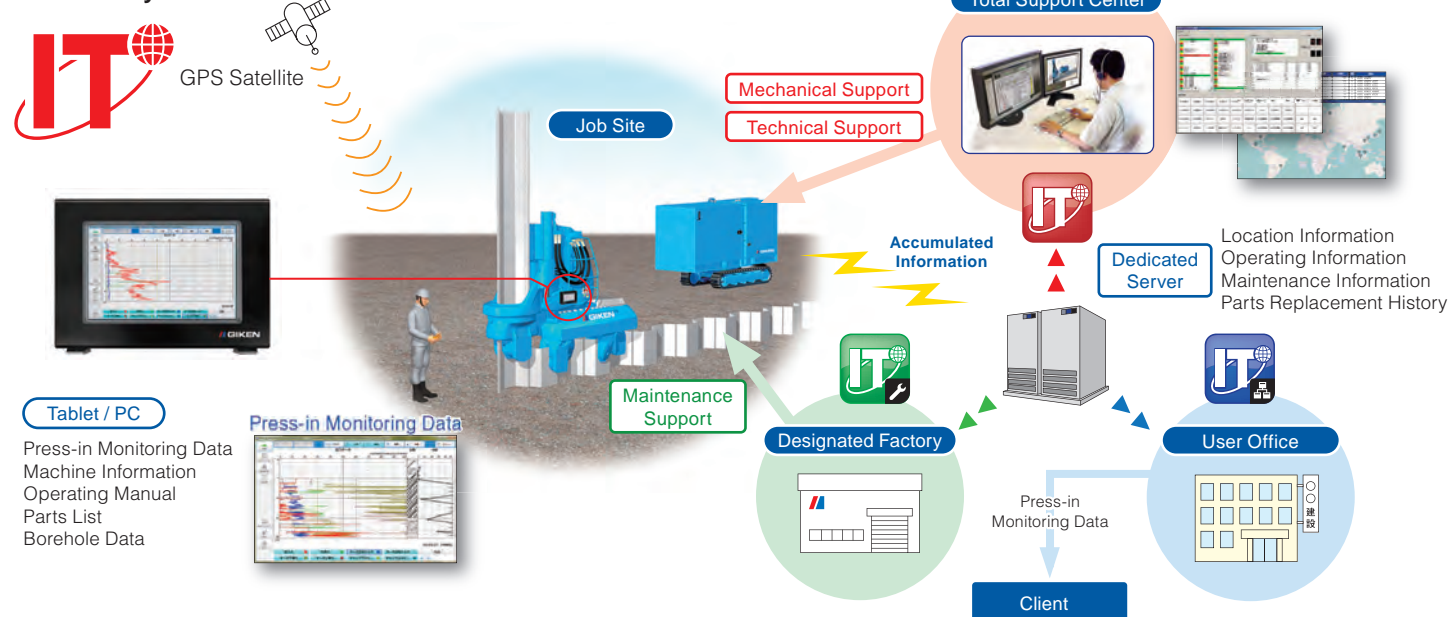

Dimensions & Specifications

Standard / Water Jetting Mode F111-400

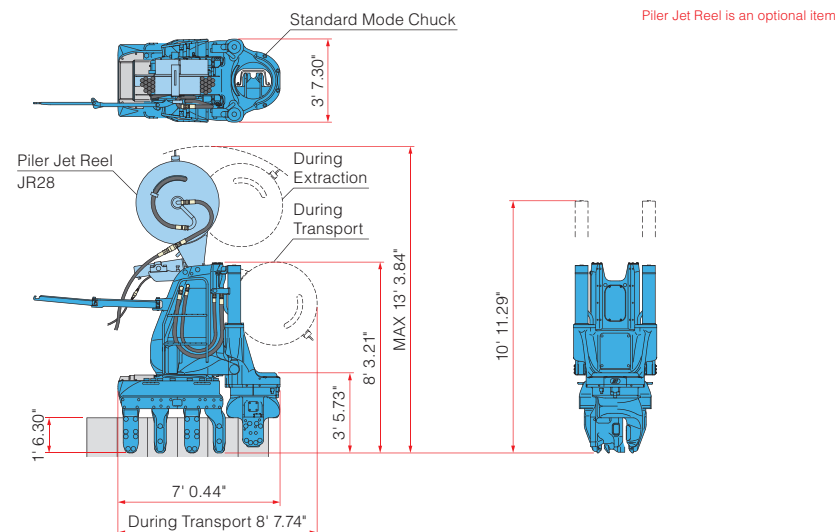

Super Crush Mode F111-C400

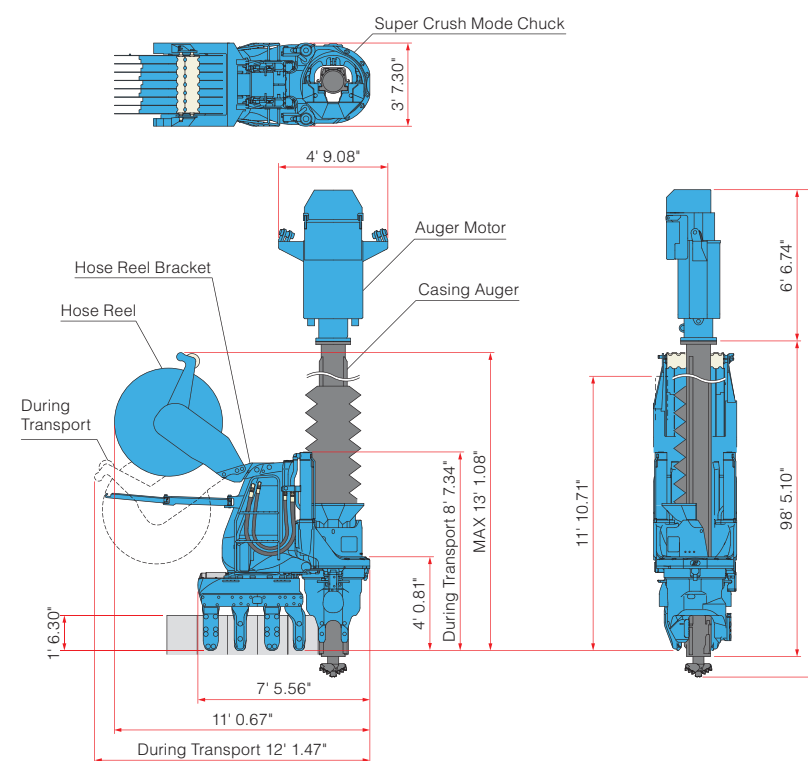

Power Unit

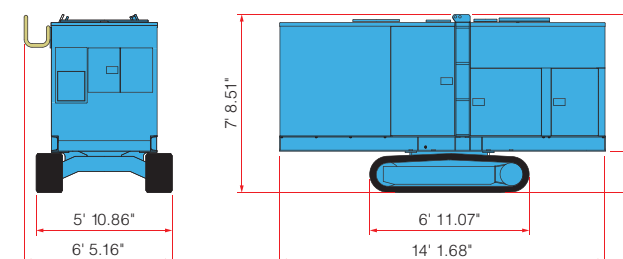

Reaction Stand

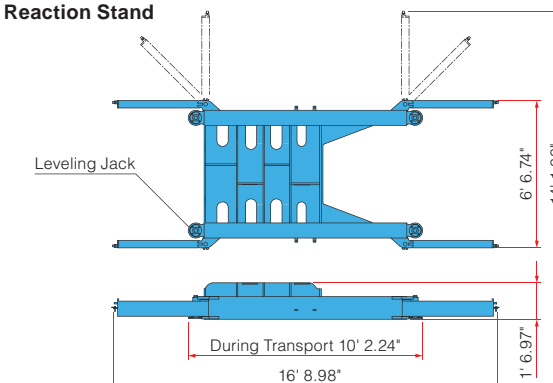

SILENT PIER F111

Applicable Sheet Piles	U Sheet Piles 15.74 in wide (SPII, SPIII, SPIV)
Max. Press-in Force	89.9 ton(US) (Super Crush Mode) 112.4 ton(US) (Standard / WJ Mode)
Max. Extraction Force	101.1 ton(US) (Super Crush Mode) 123.6 ton(US) (Standard / WJ Mode)
Stroke	33.46 in
Press-in Speed	6.56 ~ 142.71 ft/min
Extraction Speed	4.92 ~ 105.97 ft/min
Control System	Radio Control
Movement	Self-Moving

Super Crush Mode (Main Body & Hose Reel)	23369 lb
Water Jetting Mode (Main Body & Piler Jet Reel)	17350 lb
Standard Mode (Main Body)	15542 lb

Piler Jet Reel	JR28
Applicable Pile Length	Standard 55.77 ft (Max. 88.58 ft)
Mass	1807 lb

Hose Reel	HR17B
Mass (Standard)	6283 lb (including Hose Reel Bracket)

Pile Auger	PA22
Applicable Pile Length (Standard)	Max 78.74 ft*
Mass Auger Motor	4078 lb
Mass Casing Auger	19951 lb
Total Mass	24030 lb

Power Unit	EU300K4
Power Source	Diesel Engine
Rated Output Power Mode	355 HP / 1800 rpm
Rated Output Eco Mode	316 HP / 1600 rpm
Rated Output Super Eco Mode	276 HP / 1400 rpm
Fuel Tank Capacity	159 US gal
Hydraulic Reservoir	PILER ECO OIL 166 US gal
Urea Additive Tank Capacity	10 US gal
Moving Speed	0.87 mph
Mass	15983 lb (with 65.61 ft Hose)

Reaction Stand (with Leveling Jack)	
Mass	3086 lb

Standard Mode Chuck	4343 lb
Super Crush Mode Chuck	5952 lb

The above specifications are subject to alteration without prior notice