



# INVERTER POOL PUMP



INSTALLATION & OPERATION MANUAL

1. ⚠ IMPORTANT SAFETY INSTRUCTIONS.....1

2. TECHNICAL SPECIFICATIONS.....2

3. OVERALL DIMENSION (mm) .....2

4. INSTALLATION.....3

5. SETTING AND OPERATION.....5

6. WIFI OPERATION.....10

7. EXTERNAL CONTROL.....17

8. PROTECTION AND FAILURE .....19

9. MAINTENANCE .....21

10. WARRANTY& EXCLUSIONS .....21

11. DISPOSAL .....22

## 1. IMPORTANT SAFETY INSTRUCTIONS

This guide provides installation and operation instructions for this pump. If you have any other questions about this equipment, please consult your supplier.

**1.1 When installing and using this electrical equipment, basic safety precautions should always be followed, including the following:**

- **RISK OF ELECTRICAL SHOCK.** Connect only to a branch circuit protected by a ground-fault circuit-interrupter (GFCI). Contact a professionally trained and qualified electrician if you cannot verify that the circuit is protected by a GFCI.

- This pump is for use with permanently installed in-ground or above-ground swimming pools and may also be used with hot tubs and spas with a water temperature under 50°C. Due to the fixed installation method, this pump is not suggested to be used on above-ground pools that can be readily disassembled for storage.

- The pump is not submersible.

- Never open the inside of the drive motor enclosure.

**1.2 All installations must be fitted with earth leakage or residual current protection devices, having a rated residual operating current not exceeding 30mA.**

### **WARNING:**

- Fill the pump with water before starting. Do not run the pump dry. In case of dry run, mechanical seal will be damaged and the pump will start leaking.

- Before servicing the pump, switch OFF power to the pump by disconnecting the main circuit to the pump and release all pressure from pump and piping system.

- Never tighten or loosen screws while the pump is operating.

- Ensure that the inlet and outlet of the pump are unblocked with foreign matter.

## 2. TECHNICAL SPECIFICATIONS

Model	Advised Pool Volume (m <sup>3</sup> )	P1	Voltage (V/Hz)	Qmax (m <sup>3</sup> /h)	Hmax (m)	Circulation (m <sup>3</sup> /h)	
		KW				At 8m	At 10m
IP20	30~50	0.07~0.77	220~240/ 50/60	25.0	12.5	6.2~20.5	4.5~15.0
IP25	40~70	0.08~1.05		27.5	15.0	7.7~25.6	6.6~22.0
IP30	50~80	0.09~1.4		31.0	18.0	9.3~31.0	8.1~27.0
IP40	70~100	0.11~1.8		41.0	17.0	12.0~40.0	11.1~37.0

## 3. OVERALL DIMENSION (mm)

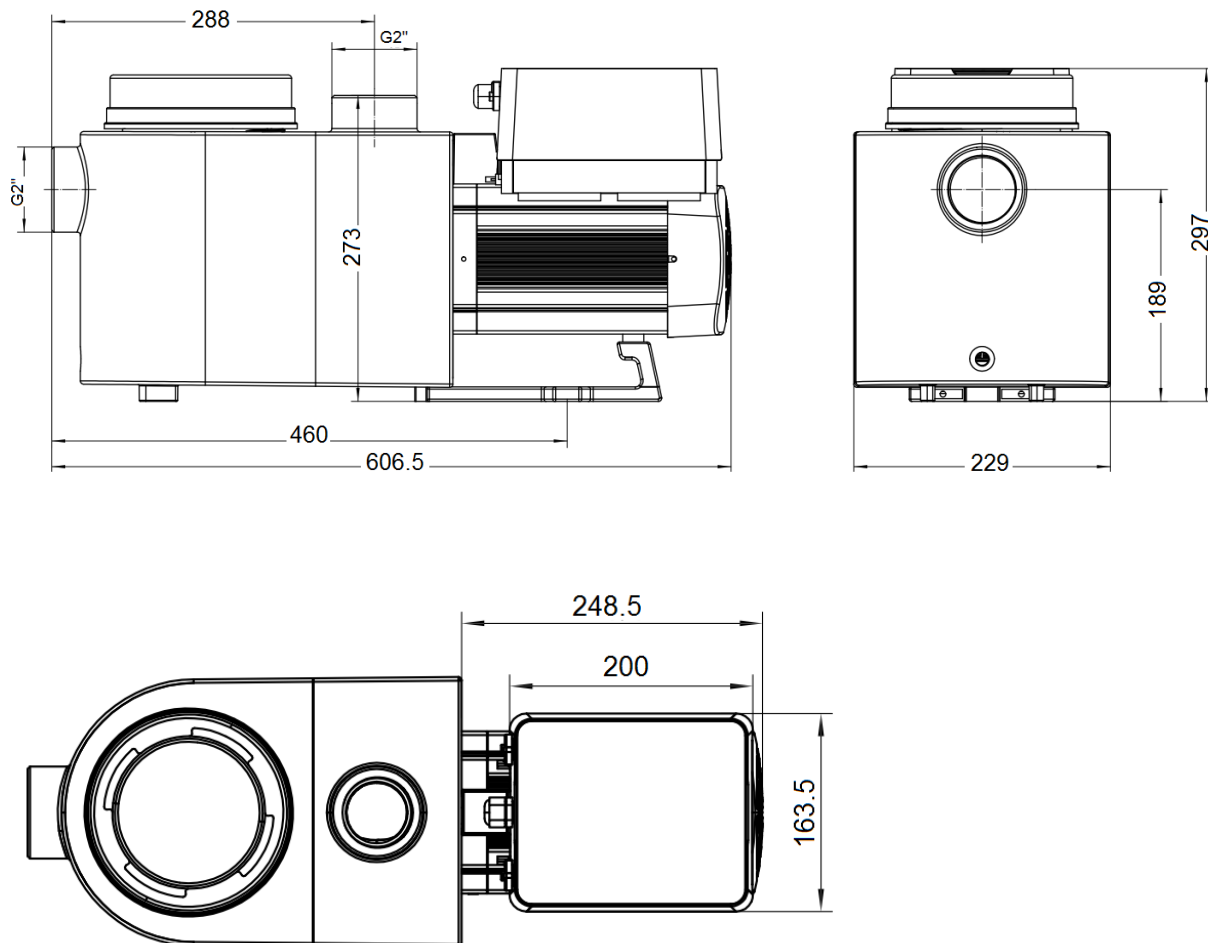

Figure 1

## **4. INSTALLATION**

### **4.1. Pump Location**

- 1) Install the pump as close to the pool as possible, to reduce friction loss and improve efficiency, use short, direct suction and return piping.
- 2) To avoid direct sunshine, heat or rain, it is recommended to place the pump indoors or in the shade.
- 3) DO NOT install the pump in a damp or non-ventilated location. Keep pump and motor at least 150mm away from obstacles, pump motors require free circulation of air for cooling.
- 4) The pump should be installed horizontally and fixed in the hole on the support with screws to prevent unnecessary noise and vibration.

### **4.2. Piping**

- 1) For optimization of the pool plumbing, it is recommended to use a pipe with size of 63mm. When installing the inlet and outlet fittings (joints), use the special sealant for PVC material.
- 2) The dimension of suction line should be the same or larger than the inlet line diameter, to avoid pump sucking air, which will affect the efficiency of the pump.
- 3) Plumbing on the suction side of the pump should be as short as possible.
- 4) For most installations we recommend installing a valve on both the pump suction and return lines, which is more convenient for routine maintenance. However, we also recommend that a valve, elbow, or tee installed on the suction line should be no closer to the front of the pump than seven times the suction line diameter.
- 5) Pump outlet piping system should be equipped with a check valve to prevent the pump from the impact of medium recirculation and pump-stopping water hammer.

### 4.3. Valves and Fittings

- 1) Elbows should be no closer than 350mm to the inlet. Do not install 90° elbows directly into the pump inlet/outlet. Joints must be tight.

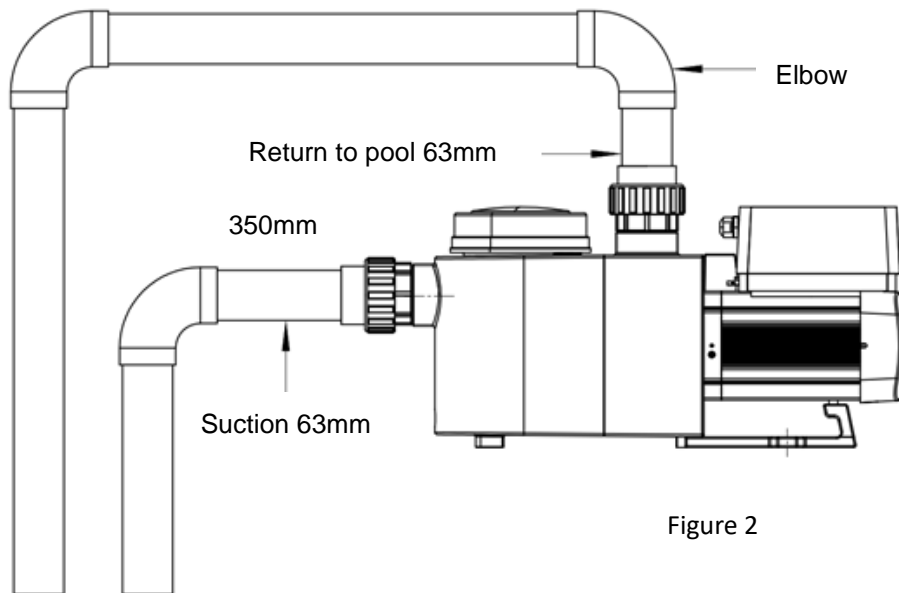

Figure 2

\* The pump inlet/outlet union size: optional with 48.5/50/60.3/63mm

- 2) Flooded suction systems should have gate valves installed on suction and return line for maintenance; however, the suction gate valve should be no closer than seven times the suction pipe diameter as described in this section.
- 3) Use a check valve in the return line where there is significant height between the return line and the outlet of the pump.
- 4) Be sure to install check valves when plumbing in parallel with other pumps. This helps prevent reverse rotation of the impeller and motor.

### 4.4 Check before initial startup

- 1) Check whether pump shaft rotates freely;
- 2) Check whether power supply voltage and frequency conform to the nameplate;
- 3) Facing the fan blade, the direction of motor rotation should be clockwise;
- 4) It is forbidden to run the pump without water.

## 4.5 Application conditions

Ambient temperature	Indoor installation, temperature range: -10~42°C
Water temperature	5°C~50°C
Salt pools	Salt concentration up to 0.5%, i.e 5g/l
Humidity	≤90% RH, (20°C±2°C)
Altitude	Not exceed 1000m above sea level
Installation	The pump can be installed max. 2m above water level;
Insulation	Class F, IP55

## 5. SETTING AND OPERATION

### 5.1 Display on control panel:

	① Power consumption
	② Running capacity / Flow rate
	③ WIFI indicator
	④ Unit of flow IMP gpm L/min US gpm m <sup>3</sup> /h
	⑤ Timer period 1 2 3 4
	⑥ Backwash/unlock
	Up/down: to change the value (capacity/flow/time)
Switch between Auto-Inverter Mode and Manual-Inverter Mode <b>Auto-Inverter Mode:</b> The running capacity will be automatically adjusted between 30%-100% according to the preset flow rate. <b>Manual-Inverter Mode:</b> The running capacity will be set manually between 30%-100% The default mode is <b>Auto-Inverter</b> mode.	
Timer setting	
On/off	

## 5.2 Startup:

When the power is switched on, the screen will be fully light for 5 seconds, the device code will be displayed, and then it will enter the normal working state. When the screen is locked, only the button



will light up; Press and hold  for more than 3 seconds, other buttons will all light up. The screen will automatically lock up when there is no operation for more than 1 minute and the brightness

of the screen is reduced by 1/3 of the normal display. Short press  to wake up the screen and observe the relevant operating parameters.

## 5.3 Self-priming

When the pump starts for the first time, the system performs the self-priming procedure to analyze the flow range of the pipeline system in actual installation. The running capacity will go up from 30% to 100% by 5% each step, and run for 180 seconds by default. (The period could be set from 180s to 1500s). This first-time self-priming is mandatory and only takes effect after the first installation or factory reset. It will not start again when the pump is turned on again. After the first-time self-priming, pump will automatically redefine the adjustable range of the flow range( eg: the default flow range of InverPro IP25 is 5-25 m<sup>3</sup>/h, after the first-time self-priming, the range may be redefined to 7-22 m<sup>3</sup>/h, user still could set the flow rate from 5 to 25 m<sup>3</sup>/h, 3 seconds after the setting is completed, the flow rate will be automatically adjusted to the actual adjustable maximum or minimum value, namely 7-22m<sup>3</sup>/h.

The default flow range for InverPro is as below:

Model	Default flow rate range
IP20	5~20 m <sup>3</sup> /h
IP25	5~25 m <sup>3</sup> /h
IP30	5~30m <sup>3</sup> /h

### Remark:



For the 1<sup>st</sup> time operation after installation, if the priming is not successful and require priming again; the end user could enter the parameter setting to active the **Boost mode** of priming (see 5.8). The adjustable period for Boost mode priming is from 600s to 1500s (default value is 600s).

If the priming is successful before the setting period, the consumer could press  for more than 3 seconds to exit and return to normal operation.



## 5.4 Backwash















User can start the backwash or fast re-circulation in any running state by pressing .

	Default	Setting range
Time	180s	Press  or  to adjust from 0 to 1500s with 30 seconds for each step
Running capacity	100%	80~100%, enter the parameter setting (see 5.8)

If backwash is completed or disabled, press and hold  for 3 seconds, the pump will return to the normal operating state before backwash.

## 5.5 Auto-Inverter Mode

Under Auto Inverter Mode, the pump could automatically detect the system pressure and adjust the speed of motor to reach the set flow.









1		Hold  for more than 3 seconds to unlock the screen;
2		Press  to start. The pump will run at a flow which is equivalent to 80% capacity after self-priming.
3	 	The flow rate could be adjusted, by pressing  or  with 1m <sup>3</sup> /h for each step.
4	 	The unit of flow rate could be changed to lpm, IMP gpm or US GPM, by pressing both   for 3 seconds
5		Press  to switch to Manual-Inverter mode

### Note:

After the first self-priming is completed, the pump will redefine the adjustable flow range. When the pump runs at a set flow/capacity for more than two minutes, the pump will record the current pipeline pressure. If the pump detects that the pipeline pressure has changed beyond a certain range due to human or other reasons, the icon of flow unit/capacity percentage symbol will start to flash. After flashing for 5 minutes, the pump will redefine the adjustable flow range according to the new pipeline pressure.











After the redefinition of flow range is complete, the pump will be able to automatically adjust running capacity to reach the set flow.

## 5.6 Manual-Inverter Mode



1		Unlock the screen, press  to shift from the Auto-Inverter mode to Manual-Inverter mode.
2	 	Press  or  to set the running capacity between 30%~100%, each step by 5%
3		Press  again to switch to Auto-Inverter mode.

## 5.7 Timer mode











The pump's on/off and running capacity could be commanded by timer, which could be programmed daily as needed.

1	Enter timer setting by pressing 	
2	Press  or  to set the local time	
3	Press  to confirm and move to time-1 setting	
4	Press  or  to choose the desired running periods and specific capacity or flow	
5	 Repeat above steps to set other 3 timers	
6	 Hold 3 seconds to save setting	
7	 or  Check 4 timers to make sure there is no invalid setting	

**Note:** Overlap setting of time will be considered as invalid, the pump will only run based on the previous valid setting.

During timer setting, if you want to return to the previous setting, hold both   for 3 seconds.

## 5.8 Parameter Setting

Restore factory setting	Under off mode, hold both   for 3 seconds
Check the software version	Under off mode, hold both   for 3 seconds
Boost mode of priming	Under off mode hold both   for 3 seconds
Enter parameter setting as below	Under off mode, hold both   for 3 seconds; If current address does no need to be adjusted, hold both   to next address

Parameter Address	Description	Default Setting	Setting Range
1	PIN3	100%	30~100%, by 5% increments
2	PIN2	80%	30~100%, by 5% increments
3	PIN1	40%	30~100%, by 5% increments
4	Self-priming/ Backwash capacity	100%	80~100%, by 5% increments
5	Control mode of Analog Input	0	0: current control 1: Voltage control

## 6. WIFI OPERATION

### 1 InverFlow Download



Android



iOS



### 2 Account registration

Register by e-mail or third-party application

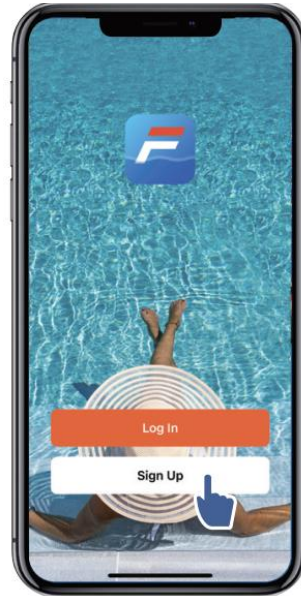

#### a. Email Registration

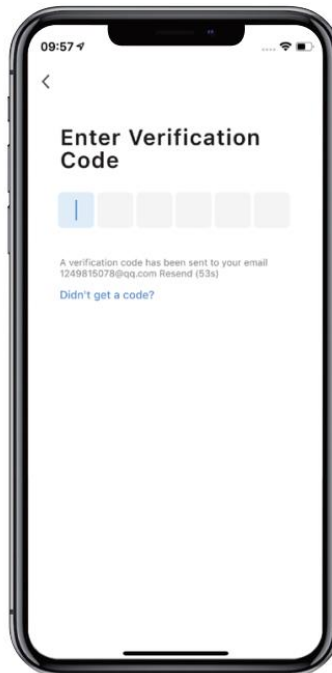
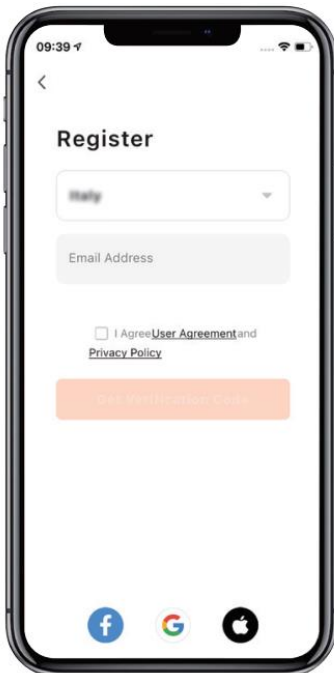

## b. Third-party application registration

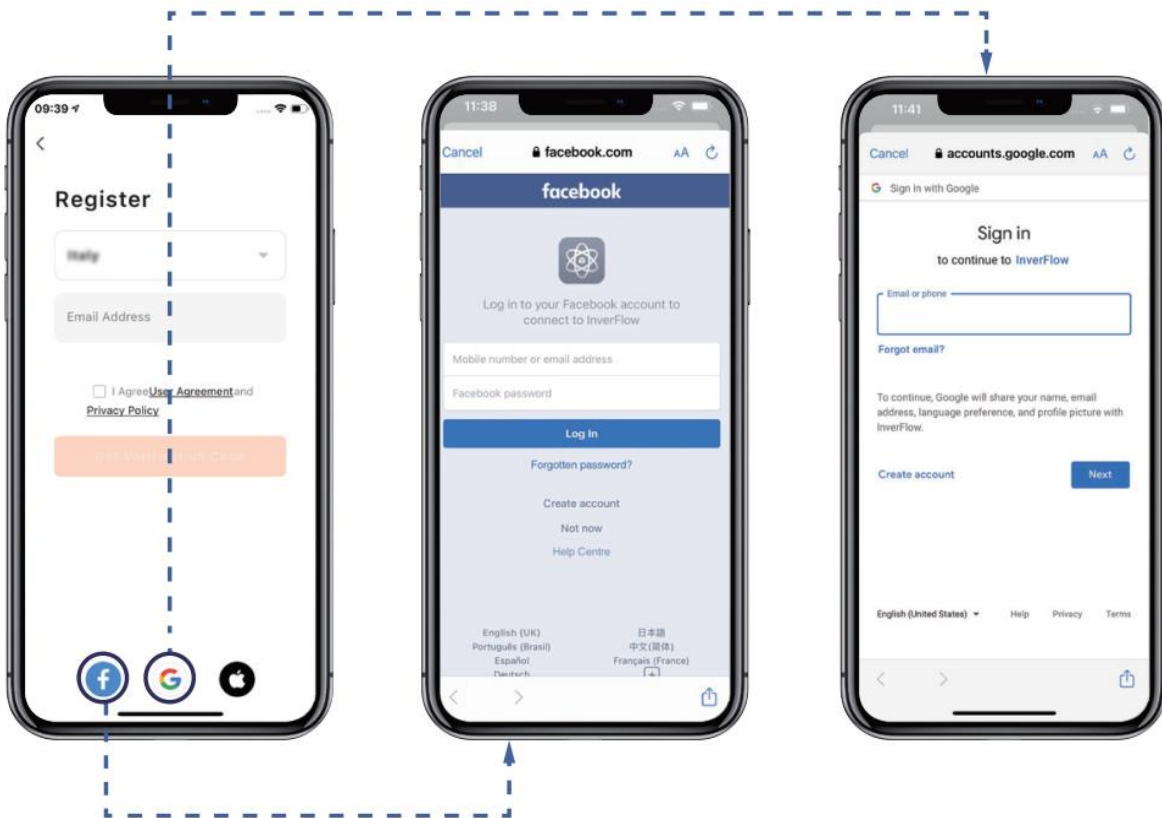

## 3 Create Home

Please set home name and choose the location of the device. (It is recommended to set the location so the weather can be shown in the App for your convenience)

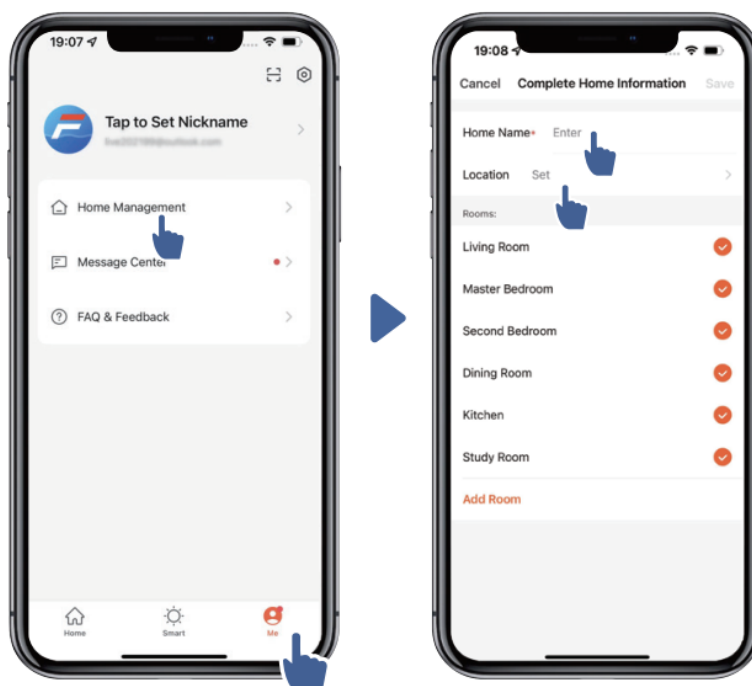



## 4 App pairing

Please make sure your pump is turned on before you start.

### Option 1 (Recommended): With Wifi and Bluetooth

(Network requirement: 2.4GHz; 2.4GHz and 5GHz into one SSID; but no separate 5GHz network)



1) Please confirm that your phone is connected to Wifi and your Bluetooth is on.

2) Press  for 3 seconds until hearing "Beep" to unlock the screen. Press  for 5 seconds until hearing "Beep" then release.  Will flash

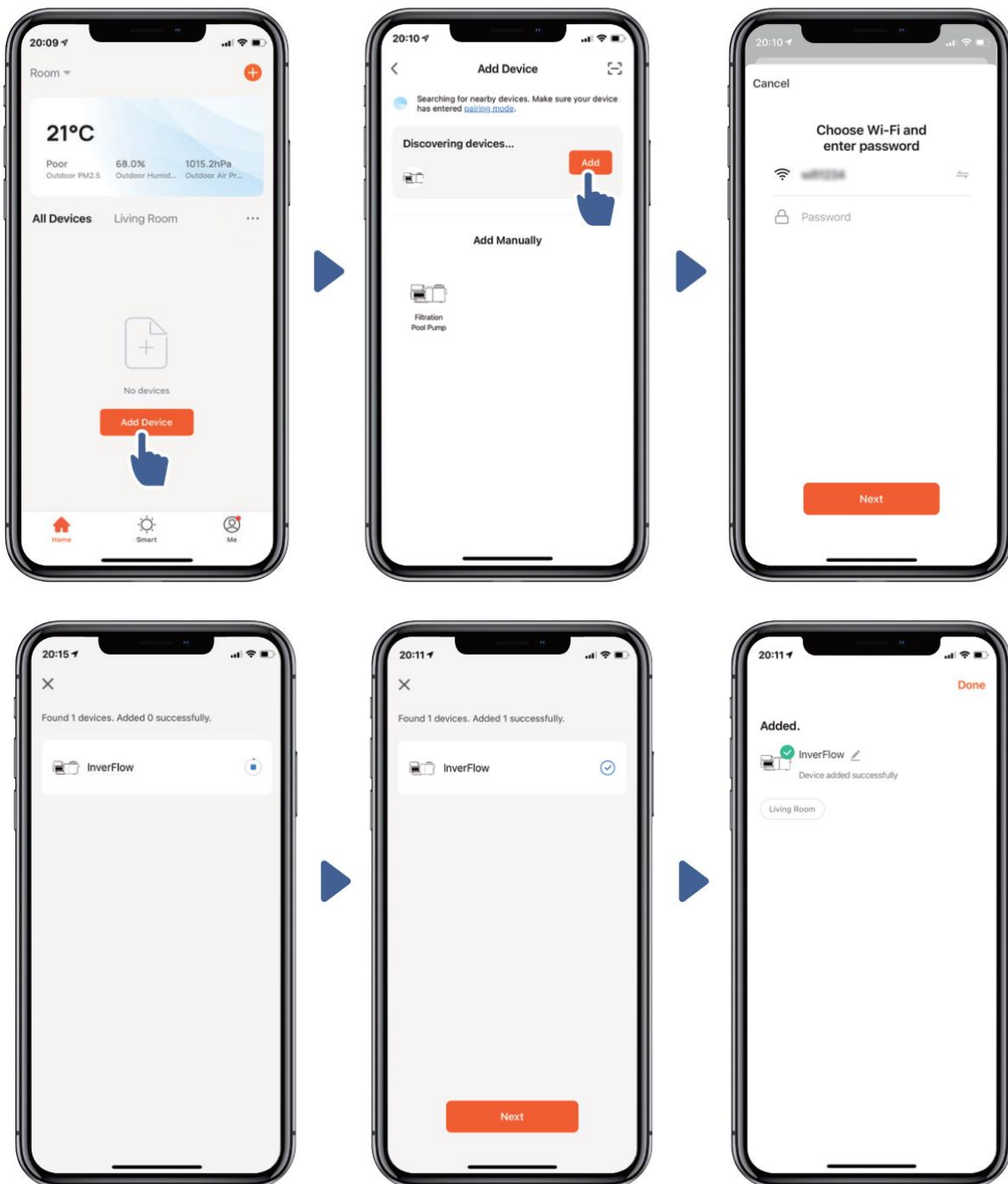
3) Click "Add Device", and then follow the instructions to pair device.



## Option 2: With Wifi (Network requirement: 2.4GHz only)

- 1) Please confirm that your phone is connected to Wifi
- 2) Press  for 3 seconds until hearing “Beep” to unlock the screen. Press  for 5 seconds until hearing “Beep” then release.  Will flash.
- 4) Click “Add Device”, and then follow the instructions to pair device.

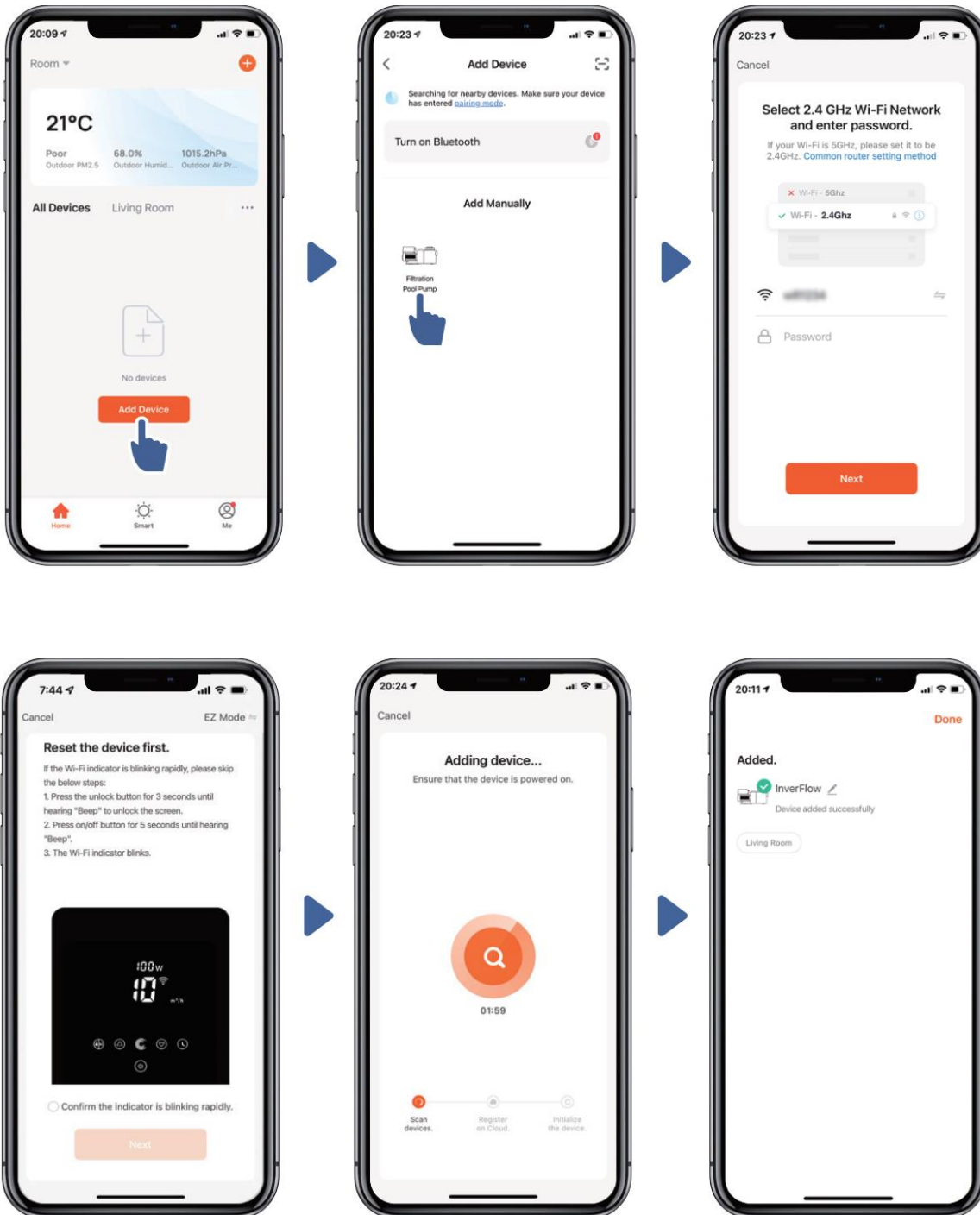

## 5 Operation

1) Using Auto Inverter mode:

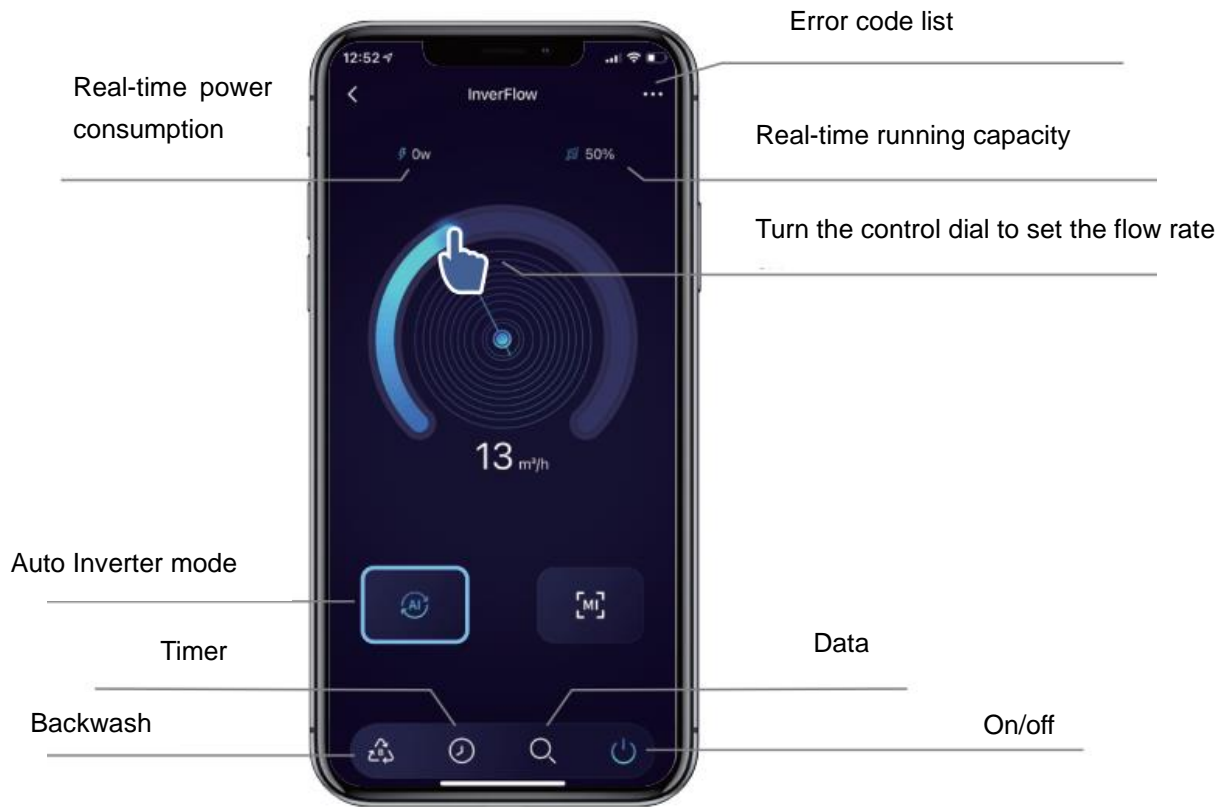

2) Using Manual Inverter mode:

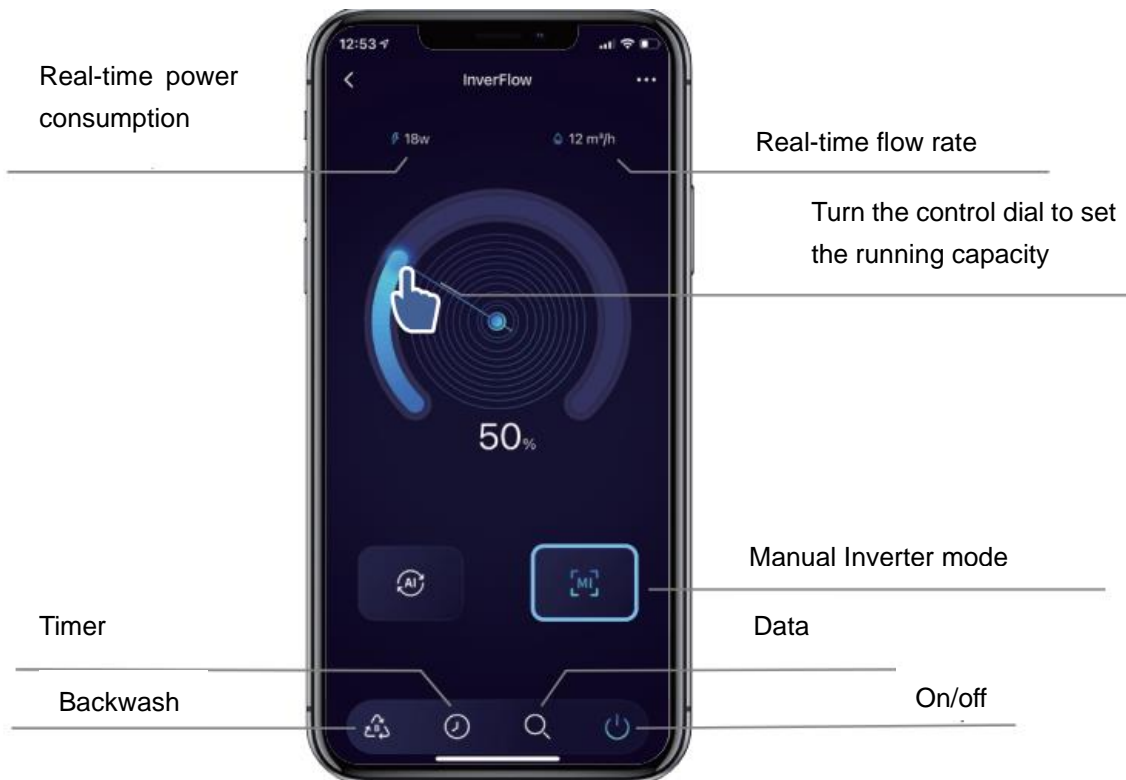



## 6 Sharing Devices with your family members

After pairing, if your family members also want to control the device, please let your family members register "InverFlow" first, and then the administrator can operate as below:

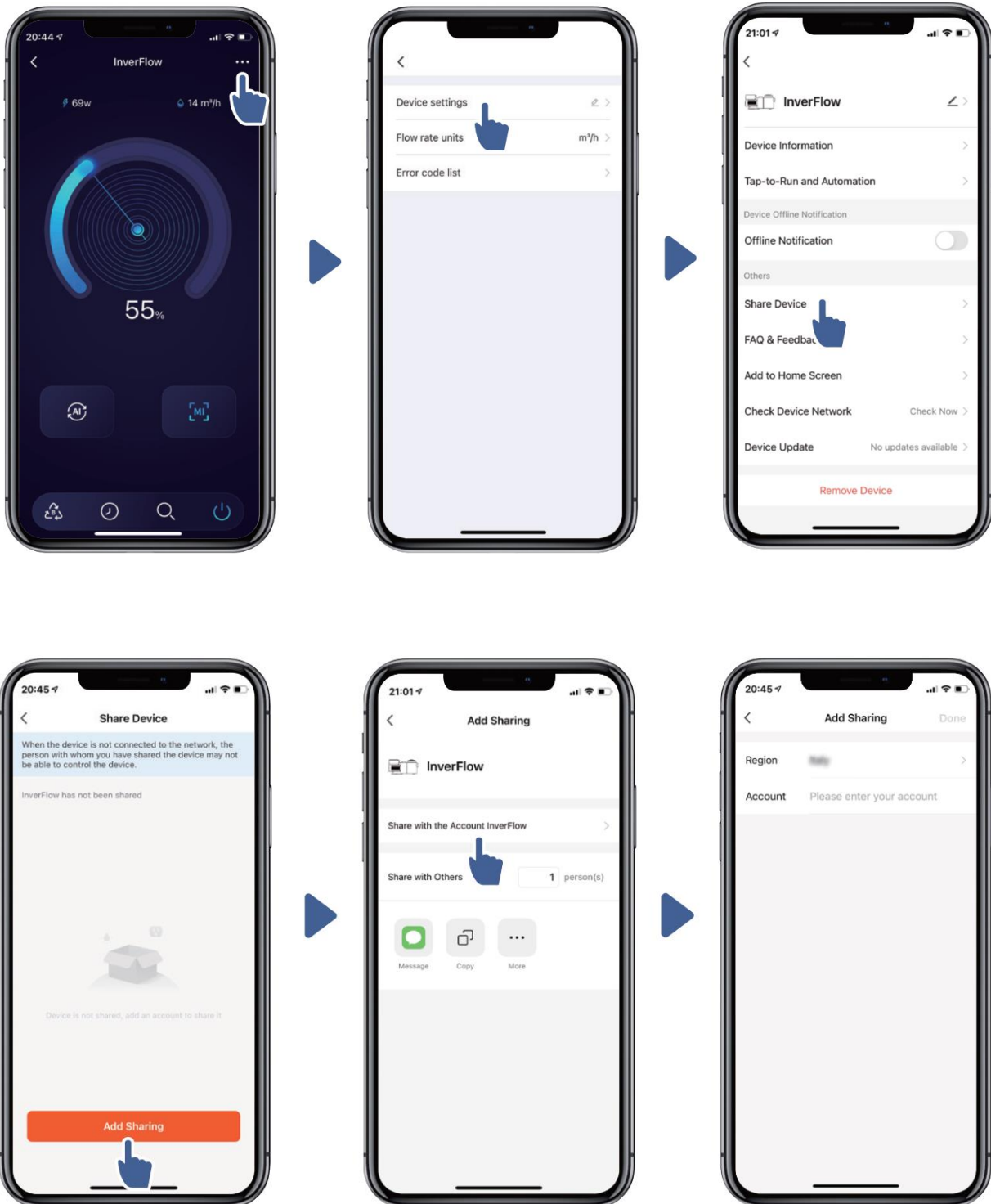

## 7 Feedback

If you have any problem while using, welcome to send feedback.

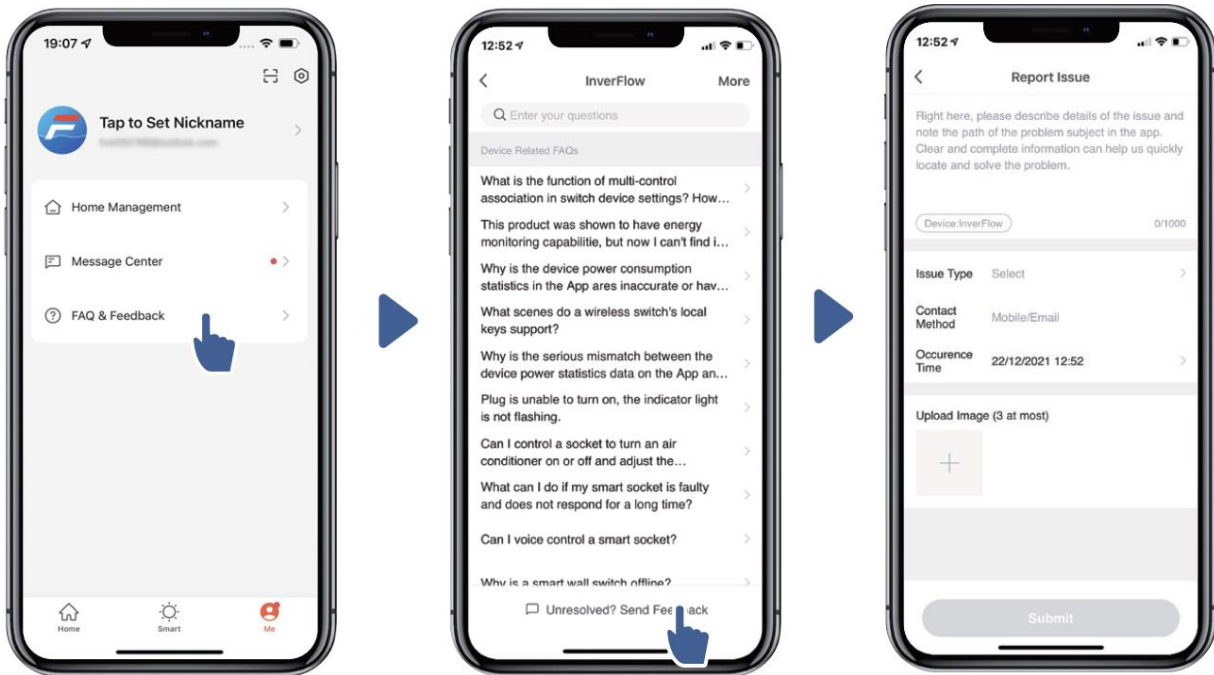

Notice:

- 1) Weather forecast is just for reference;
- 2) The power consumption data is for reference only, as it may be affected by network problems and imprecision of the calculation.
- 3) App is subject to updates without notice.

## 7. EXTERNAL CONTROL

External control can be enabled via following contacts. If more than one external control is enabled, the priority is as below: Digital Input > Analog Input > RS485 > Panel control

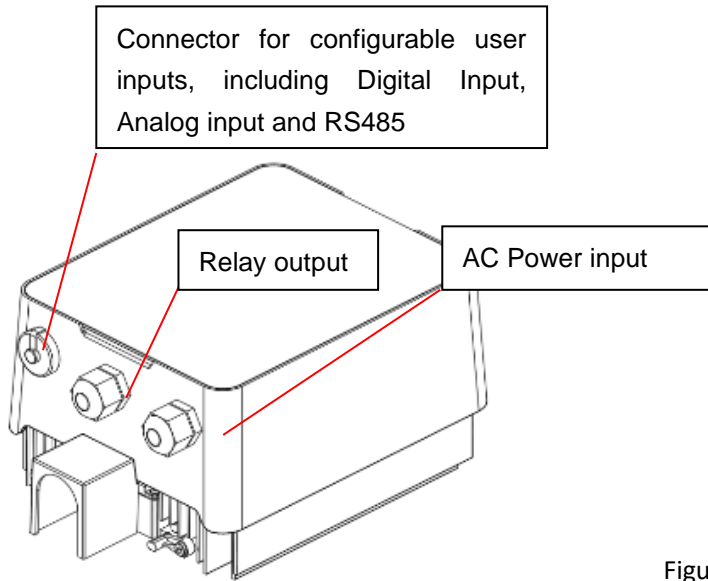

Figure 4

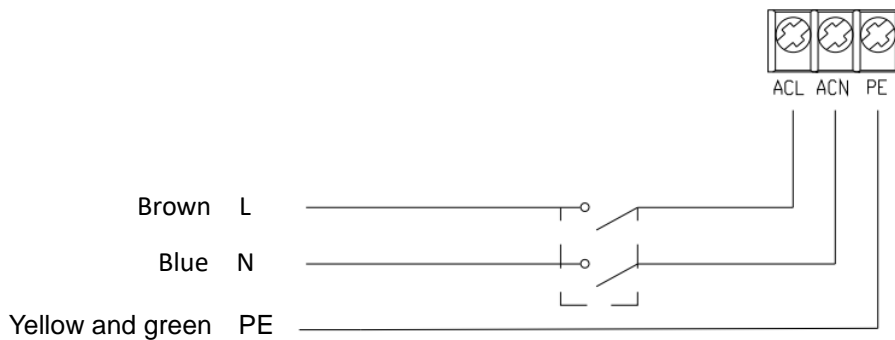
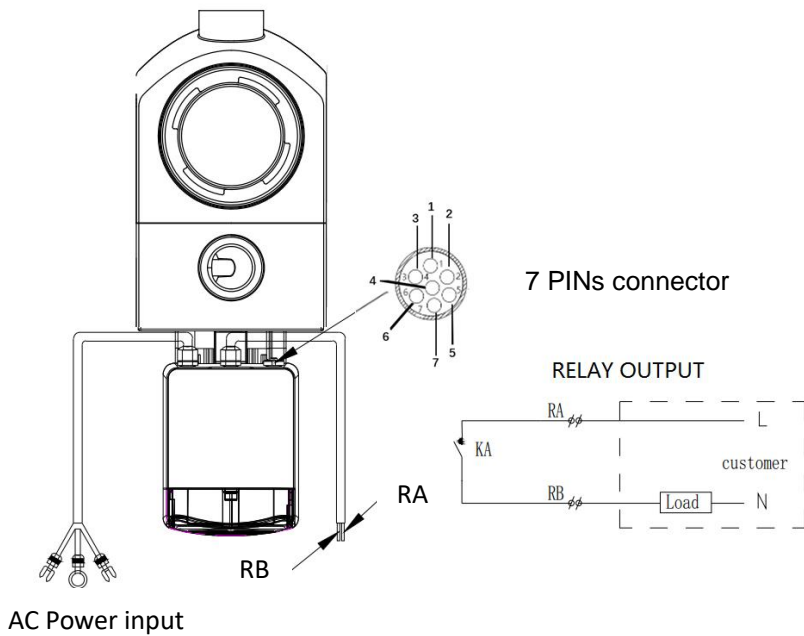

Figure 5

Name	Color	Description
PIN 1	Red	Digital Input 4
PIN 2	Black	Digital Input 3
PIN 3	White	Digital Input 2
PIN 4	Grey	Digital Input 1
PIN 5	Yellow	Digital Ground
PIN 6	Green	RS485 A
PIN 7	Brown	RS485 B
PIN 8	Blue	Analog Input 0 (0-10V or 0~20mA)
PIN 9	Orange	Analog Ground

Remark: Above table sums up the associated input signals. When Analog input is required, 9 PINS connector with wirings will be provided.

#### a. Digital input

Running capacity is determined by the state of digital input, (5 芯线)

When PIN4 connect with PIN5, the pump will be mandatory to stop; if disconnected, the digital control will be invalid;

When PIN3 connect with PIN5, the pump will be mandatory to run at 100%; if disconnected, the control priority will be back on panel control;

When PIN2 connect with PIN5, the pump will be mandatory to run at 80%; if disconnected, the control priority will be back on panel control;

When PIN1 connect with PIN5, the pump will be mandatory to run at 40%; if disconnected, the control priority will be back on panel control;

The capacity of inputs (PIN1/PIN2/PIN3) could be modified according to the parameter setting.

Running capacity is determined by the state of digital input, (4 芯线)

When all PINs (PIN1/2/3/5) are disconnected, the pump will be mandatory to stop;

When PIN3 connect with PIN5, the pump will run at 100%; when PIN3 is disconnected to PIN5, the pump is OFF;

When PIN2 connect with PIN5, the pump will run at 80%; when PIN2 is disconnected to PIN5, the pump is OFF;

When PIN1 connect with PIN5, the pump will run at 40%; when PIN1 is disconnected to PIN5, the pump is OFF;

The capacity of inputs (PIN1/PIN2/PIN3) could be modified according to the parameter setting.

#### b. Analog Input (optional):

When connected with PIN8 and PIN9, running capacity could be determined by 0~10V analog voltage signal or 0~20 mA analog current signal.

The following table shows the relationship between the analog signal on input and the set value to be activated:

Analog control	Motor Stops	Motor Runs
Current (mA)	2.6~5.8 mA	5.8~20 mA

Voltage (V)	1.3~2.9 V	2.9~10 V
-------------	-----------	----------

The default control mode is by current signal, if you want to change to voltage signal, please enter the parameter setting. (see 5.8)

**c. RS485:**

To connect with PIN6 and PIN7, the pump could be controlled via Modbus 485 communication protocol.

**d. Relay output (optional):**

Connect terminal L & N to enable external control. An additional on-off Relay is necessary while bearing power is greater than 500W (2.5A).

## 8. PROTECTION AND FAILURE

### 8.1 High Temperature Warning and Speed Reduction

In "Auto-Inverter/Manual-Inverter Mode" and "Timer mode" (except backwash/self-priming), when the module temperature reaches the high temperature warning trigger threshold (81°C), it enters the high temperature warning state; when the temperature drops to the high temperature warning release threshold (78°C), the high temperature warning state is released. The display area alternately displays AL01 and running speed or flow.

AL01 And running speed or flow

- a) If current operating capacity is higher than 85%, the running capacity will be automatically reduced by 15%;
- b) If current operating capacity is higher than 70%, the running capacity will be automatically reduced by 10%;
- c) If current operating capacity is lower than 70%, the running capacity will be automatically reduced by 5%.
- 4) Suggestion for non-first displayed of AL01: check the module temperature every 2 minutes. Compared with the temperature in the previous period, for every 1-degree Celsius increase, the speed will decrease by 5%.

### 8.2 Undervoltage protection

When the device detects that the input voltage is less than 200V, the device will limit the current running speed

When input voltage is less than or equal to 180V, the running capacity will be limited to 70%;  
 When the input voltage range is within 180V ~ 190V, the running capacity will be limited to 75%;  
 When the input voltage range is within 190V ~ 200V, the running capacity will be limited to 85%.

### 8.3 Trouble shooting

<b>Problem</b>	<b>Possible causes and solution</b>
<b>Pump does not start</b>	<ul style="list-style-type: none"> <li>• Power Supply fault, disconnected or defective wiring.</li> <li>• Fuses blown or thermal overload open.</li> <li>• Check the rotation of the motor shaft for free movement and lack of obstruction.</li> <li>• Because of long time lying idle. Unplug the power supply and manually rotate motor rear shaft a few times with a screwdriver.</li> </ul>
<b>Pump does not prime</b>	<ul style="list-style-type: none"> <li>• Empty pump/strainer housing. Make sure the pump/strainer housing is filled with water and the O ring of cover is clean.</li> <li>• Loose connections on the suction side.</li> <li>• Strainer basket or skimmer basket loaded with debris.</li> <li>• Suction side clogged.</li> <li>• Distance between pump inlet and liquid level is higher than 2m, the installation height of pump should be lowered.</li> </ul>
<b>Low Water Flow</b>	<ul style="list-style-type: none"> <li>• Pump does not prime.</li> <li>• Air entering suction piping.</li> <li>• Basket full of debris.</li> <li>• Inadequate water level in pool.</li> </ul>
<b>Pump being noisy</b>	<ul style="list-style-type: none"> <li>• Air leak in suction piping, cavitation caused by restricted or undersized suction line or leak at any joint, low water level in pool, and unrestricted discharge return lines.</li> <li>• Vibration caused by improper installation, etc.</li> <li>• Damaged motor bearing or impeller (need to contact the supplier for repair).</li> </ul>

#### 8.4 Error code

When the device detects a failure (except for the running capacity reduction strategy and 485 communication failure), it will power off automatically and display the failure code. After power off for 15 seconds, check if the failure is cleared, if cleared, it will resume to start.

<b>Item</b>	<b>Error Code</b>	<b>Description</b>
1	E001	Abnormal input voltage
2	E002	Output over current
3	E101	Heat sink over heat
4	E102	Heat sink sensor error
5	E103	Master driver board error
6	E104	Phase-deficient protection
7	E105	AC current sampling circuit failure
8	E106	DC abnormal voltage
9	E107	PFC protection

10	E108	Motor power overload
11	E201	Circuit board error
12	E203	RTC time reading error
13	E204	Display Board EEPROM reading failure
14	E205	Communication Error
15	E207	No water protection
16	E208	Pressure sensor failure

Note:

1. When causes for E002/E101/E103 is displayed, the device will resume working automatically, however when it appears a fourth time, the device will stop working, to resume operation, unplug the device and plug in & restart again.

## 9. MAINTENANCE

Empty the strainer basket frequently. The basket should be inspected through the transparent lid and emptied when there is an evident stack of rubbish inside. The following instructions should be followed:

- 1). Disconnected the power supply.
- 2). Unscrew the strainer basket lid anti-clockwise and remove.
- 3). Lift up the strainer basket.
- 4). Empty the trapped refuse from the basket, rinse out the debris if necessary.

**Note: Do not knock the plastic basket on a hard surface as it will cause damage**

- 5). Inspect the basket for signs of damage, replace it.
- 6). Check the lid O-ring for stretching, tears, cracks or any other damage
- 7). Replace the lid, hand tightening is sufficient.

**Note: Periodically inspect and clean the strainer basket will help prolong its life.**

## 10. WARRANTY & EXCLUSIONS

Should a defect become evident during the term of warranty, at its option, the manufacturer will repair or replace such item or part at its own cost and expense. Customers need to follow the warranty claim procedure in order to obtain the benefit on this warranty.

The guarantee will be void in cases of improper installation, improper operation, inappropriate use,

tampering or using non-original spare parts.

## 11. DISPOSAL



When disposing the product, please sort the waste products as electrical or electronic product waste or hand it over to the local waste collection system.

The separate collection and recycling of waste equipment at the time of disposal will help ensure that it is recycled in a manner that protects human health and the environment. Contact your local authority for information on where you can drop off your water pump for recycling

IP7B-2