



PRO WING®
BGS-F101 SPEEDSTILE
RETRACTABLE BARRIER
DC BRUSHLESS MOTORISED

BoomGate®
Systems (PTY) LTD

Reg.No. 98/23505/07

Engineering Access Control



MARKET LEADER

- This versatile product is suitable for most entrance control.
- Boomgate Systems offer a wide range of options to compliment any prestige installation.
- Exported worldwide.



APPLICATIONS:

- Banks, reception areas, airports, leisure facilities, museums and railway stations.
- Any application where high volume access needs to be controlled with a medium level of security.

DESIGNED FOR:

- Interior or covered exterior.
- Extreme access control with high through put.

CONFIGURATIONS:

- Narrow lane gate opening 600mm.
- Wide lane gate opening 900mm for trolleys and wheelchair access.

SECURITY LEVEL RATING: (LOW / MEDIUM / HIGH / ULTRA SECURE)

TYPE	PEDESTRIAN GATE	LOW	MEDIUM	HIGH	ULTRA SECURE
RETRACTABLE	MOTORISED	X	X		



DEFINITION

- Security rating is based on when the turnstile is in the locked position.
- Level of security is based on entry through the turnstile without unlocking the rotor and the use of access control system.



FEATURES:

1 ANTI-CRASH

Compared to traditional swing barriers, our Pro Wing® Speedstile Retractable have an anti-crash system. When a pedestrian tries to push the flap to pass without authorisation, the flap will auto-lock in a set degree and then automatically go back to the original position without the flap crashing.

2 ADJUSTABLE SPEED

Our Pro Wing® Speedstile Retractable allows you to set the opening and closing speed according to your requirements. When using a wider or higher flap, the speed can be adjusted to accommodate the bigger size.

3 EASY INTEGRATION

The Access Reader or Push Button can be used to trigger the Pro Wing® Speedstile Retractable to open via a simple dry contact signal. After the delay timer has elapsed, the Retractable Barrier will automatically close by itself in a specific time (this time can be set from 3 - 60 seconds).

4 DOUBLE SAFETY

An IR sensor is installed to auto reverse the gate should an obstacle be detected during closing. This feature prevents the gate from closing and hitting a pedestrian or object that is still in the passage lane. BGS-F101 control system offers two logic modes with IR. Basic logic use for simple passage control (4 pairs IR at least), with a tailgating logic mode with additional IR beams.

5 EMERGENCY

Our Pro Wing® Speedstile Retractable board has an emergency interface for an emergency signal. The Pro Wing® Retractable Speedstile will open in the event that the signal is triggered **in case of a fire**.

6 OPERATIONAL MODES

- Entry and Exit
- Entry Only
- Exit Only
- Free Exit
- Free Entry
- Evacuation Mode





SPECIAL DESIGN FEATURES:

- The modular compact design with removable access doors allows for easy installation and maintenance.
- The Pro Wing® Speedstile Retractable is designed with user safety in mind - there are no sharp edges or rough surfaces.
- Fully fire regulations approved.
- All external surfaces have a smooth brushed finish.
- Mean time between failure is 5 million.
- BGS-F101 open and close speed up to 0.3 sec, which allows continuous passage of up to 45 people per minute.
- BGS-F101 control system offers two logic working modes with IR. Simple logic use for simple passage.



TECHNOLOGY:

BGS-F101 is a DC brushless motorized Speedstile Retractable complete with control kit inside. It has a slim, elegant design and minimal foot print while offering widest opening clearance to allow big boxes, trolleys, wheelchairs, baby strollers or users with large luggage to pass through with comfort.



WARRANTY



1 YEAR
ELECTRICAL WARRANTY



3 YEAR
MECHANICAL WARRANTY



TECHNICAL SPECIFICATION:

DESCRIPTION

Power:

Motor/Rate Power:

Passing Speed:

MTBF:

Power Fail Options:

System Integration:

Tamper Alarm:

PARAMETERS

AC100~240V, 50/60Hz

DC Brushless Servo Motor, 40W/24V

35 – 50 person/min, adjustable

More than 5 million

Glass wings released on power failure to be moved into cabinet.

Can integrate with any access control or ticketing systems.

- Tailgating
- Invalid direction



PACKAGING SPECIFICATION:

DESCRIPTION

One Double Unit:

Two Single Units:

PARAMETERS

T.B.A.

T.B.A.



*Fumigation Free
Wooden Cases*

PRO WING® BGS-F101 SPEEDSTILE RETRACTABLE (DC Brushless Motorised)

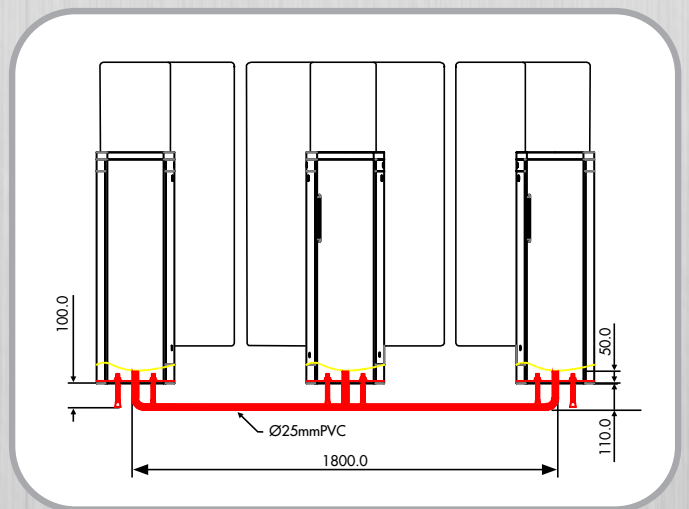
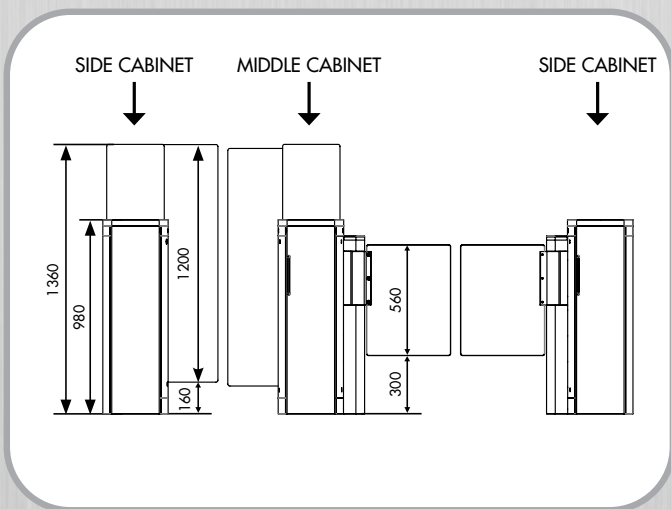
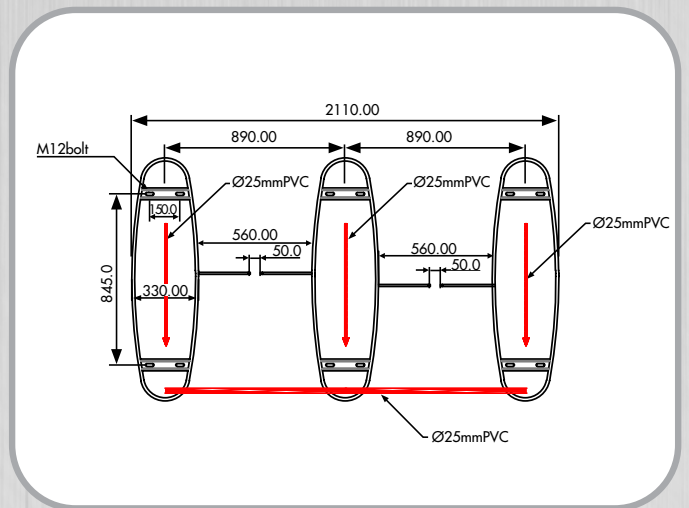
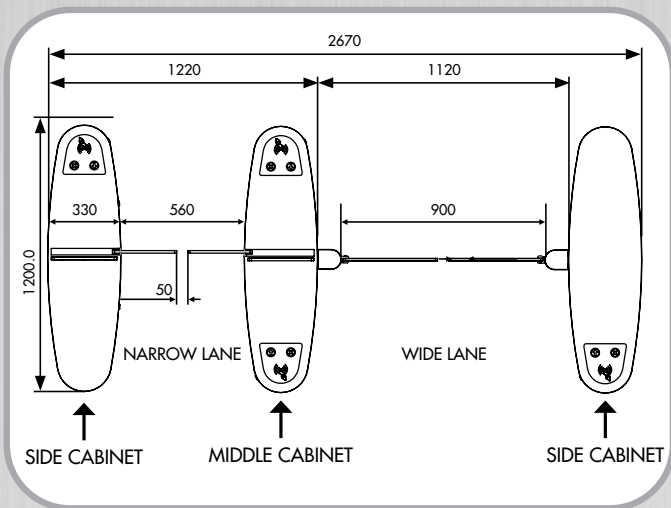
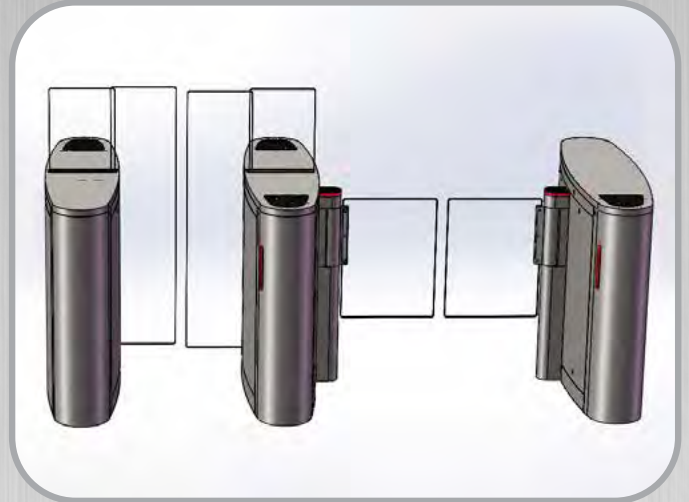
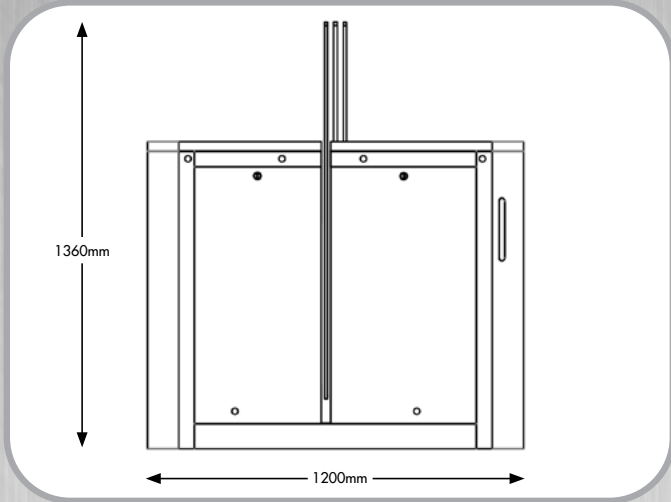

*Due to continuous product development, products and designs are subject to change without notice.

ASSOCIATED PRODUCTS

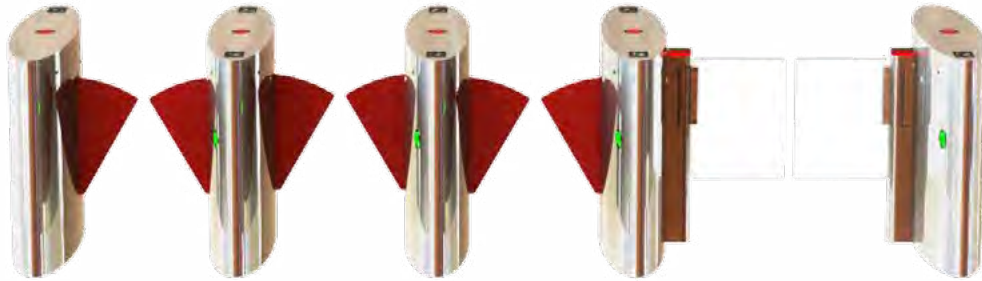

PRO WING® BGS-A201 SPEEDSTILE FLAP BARRIER



PRO WING® BGS-T401 SPEEDSTILE 180° SWING BARRIER



**TYPHOON™ BGS-101
180° SWING GATE**



**TYPHOON™ BGS-A1013
90° & 180° SWING GATE**



BoomGate[®]
Systems (PTY) LTD

Reg.No. 98/23505/07

Engineering Access Control



JOHANNESBURG BRANCH: Tel: +27 11 674 4441 • Fax: +27 11 674 4450 • Email: boomgate@global.co.za

18 Minerva Avenue, Leaglen, Florida, Roodepoort, SOUTH AFRICA

CAPE TOWN BRANCH: Tel: +27 21 551 0849 • Fax: +27 21 551 8627 • Email: salesct2@boomgatesystems.co.za

Unit 2 Crest Park, 12B Longclaw Drive, Montague Gardens, Cape Town, SOUTH AFRICA

www.boomgatesystems.co.za

Manufacturers & Suppliers of:

Traffic Barriers • High Security Spike Barriers • Road Blockers • Turnstiles • Security Booths • Pedestrian Barriers
Paraplegic Gates • Speed Gates • Bollards • Goosenecks • Magnetic Locks • Metal Enclosures • Rubber Islands

© Boomgate Systems (Pty) Ltd 2015

JN2925