

# SCORPION™

## SINGLE DIRECTIONAL SPIKE BARRIER



**BoomGate**<sup>®</sup>  
**Systems** (PTY) LTD

Reg.No. 98/23505/07 Engineering Access Control



# FLUSH MOUNT



**Boomgate Systems Scorpion™ Spike Barrier**  
is known for High Quality Reliable access control.

Individual Stainless Steel return spring per spike. The spike barrier has an ultra quiet mechanism, compared to lesser models.

## APPLICATION:

- To control traffic flow in one direction and disable tyres travelling in wrong directions.
- The Single Direction Manual Spikes is suitable for shopping malls, airports, office blocks, casino's etc., where single directional traffic flow is required.

## AVAILABLE OPTIONS:

- Flush Mount, 1M and 500mm sections. M/S galvanised frame with yellow powder coated spikes.

## UNIQUE FEATURES:

### Mechanism:

- 2 x CNC Machine brass bushes for spike.
- Each spike has 1 x heavy-duty rubber damper to reduce noise.
- Each spike may be removed individually.
- Flush mount spike is only 96mm from road surface.

### Technology:

- 1 x Stainless Steel return spring per spike.
- 1 x Heavy Duty Rubber Stop per spike.
- Lowers mechanical stress, to increase operational life.
- 2 x CNC Machine brass bushes allows for operation without lubrication.
- CNC laser cut spikes.

### Manufacturing Options:

- 1M Flush Mount options.
- 500mm Flush Mount sections.
- Mild Steel, Galvanised, Standard with Yellow powder coated sharpened spikes.

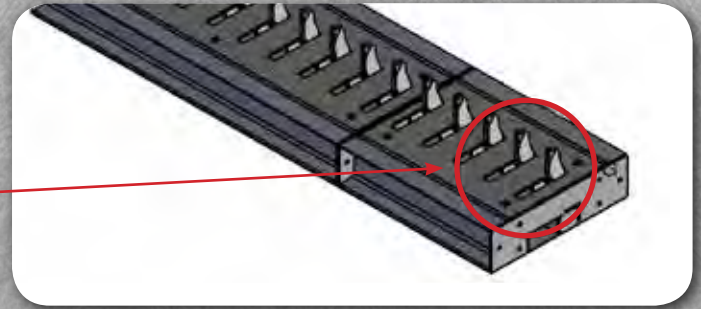
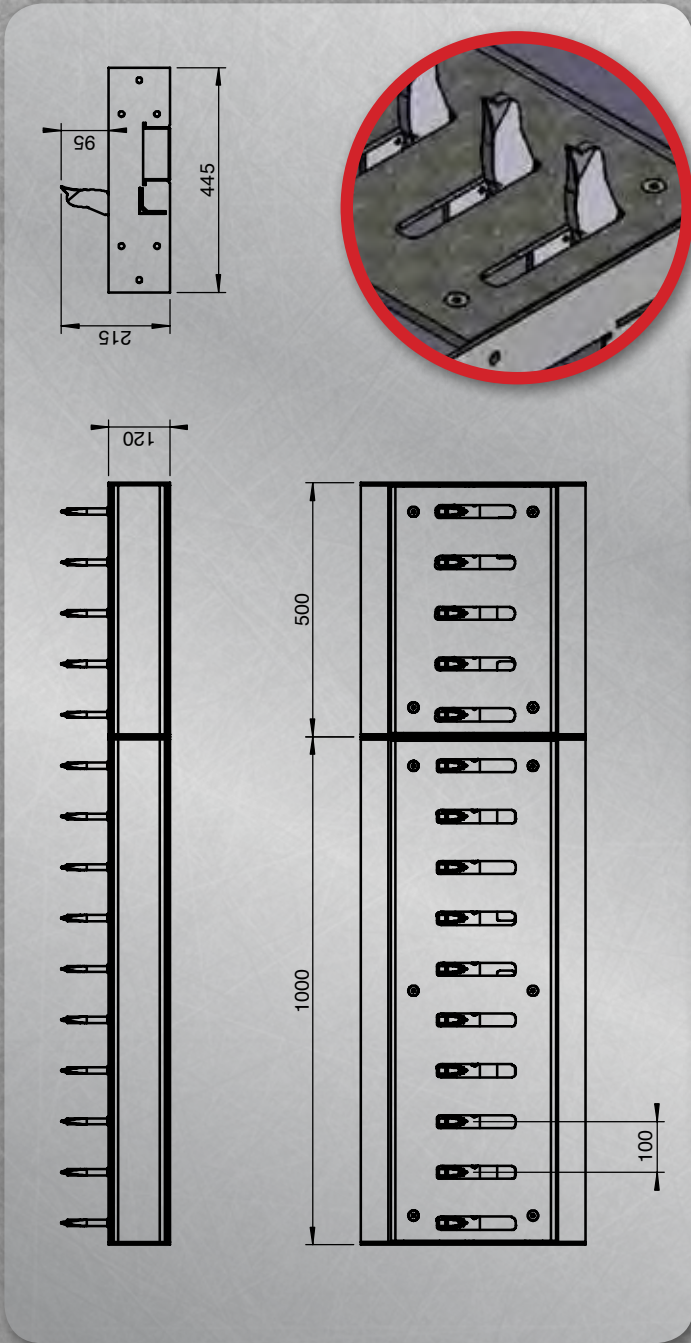
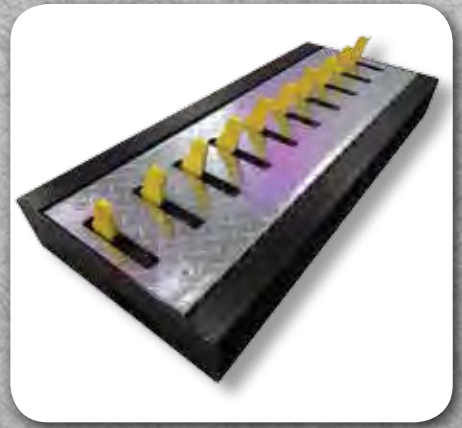
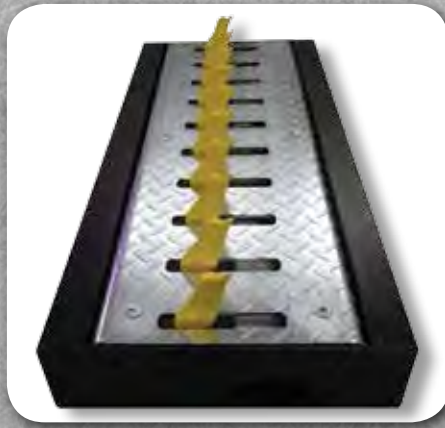

## TECHNICAL SPECIFICATIONS FOR SPIKE BARRIER:

- Spikes are individually spring loaded.
- Maintenance free robust mechanism.
- Heavy duty rubber stop behind each spike.
- 2 x Brass bushes with each spike. CNC cut and machined.
- 1 x Stainless Steel Return Spring with each spike.
- Compact robust consists of 500mm and 1M.
- Precision laser cut components are CNC Machined.



# SURFACE MOUNT

MARKET LEADER



**Boomgate Systems Scorpion™ Spike Barrier**  
is known for High Quality Reliable access control.

**Individual Stainless Steel return spring per spike. The spike barrier has an ultra quiet mechanism, compared to lesser models.**

## APPLICATION:

- To control traffic flow in one direction and disable tyres travelling in wrong direction.
- The Surface Mount Single Direction Manual Spikes is suitable for shopping malls, airports, office blocks, casino's etc.
- When flush mount can't be installed into the road surface e.g. Multi-story Parkades.

## AVAILABLE OPTIONS:

- Surface Mount 1M and 500mm sections. M/S galvanised frame with yellow powder coated spikes.

## UNIQUE FEATURES:

### Mechanism:

- 2 x CNC Machine brass bushes for spike.
- Each spike has 1 x heavy-duty rubber damper to reduce noise.
- Each spike may be removed individually.
- Surface mount spikes is only 125mm above road surface to minimise the risk of low vehicles.

### Technology:

- 1 x Ultra Long Life Stainless Steel return spring per spike.
- 1 x Heavy Duty Rubber Stop per spike.
- Lowers mechanical stress, to increase operational life.
- 2 x CNC Machine brass bushes allows for operation without lubrication.
- CNC laser cut spikes.

### Manufacturing Options:

- 1M Surface Mount options.
- 500mm Surface Mount sections.
- Mild Steel, Galvanised, Standard with Yellow powder coated sharpened spikes.
- Sloped end plates.

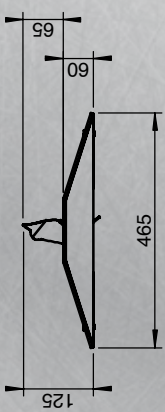

## TECHNICAL SPECIFICATIONS FOR SPIKE BARRIER:

- Spikes are individually spring loaded.
- Maintenance free robust mechanism.
- Heavy duty rubber stop behind each spike.
- 2 x Brass bushes with each spike. CNC cut and machined.
- 1 x Stainless Steel Return Spring with each spike.
- Compact robust consists of 500mm and 1M sections.
- End plate to eliminate tyre damage.
- Precision laser cut components are CNC Machined.

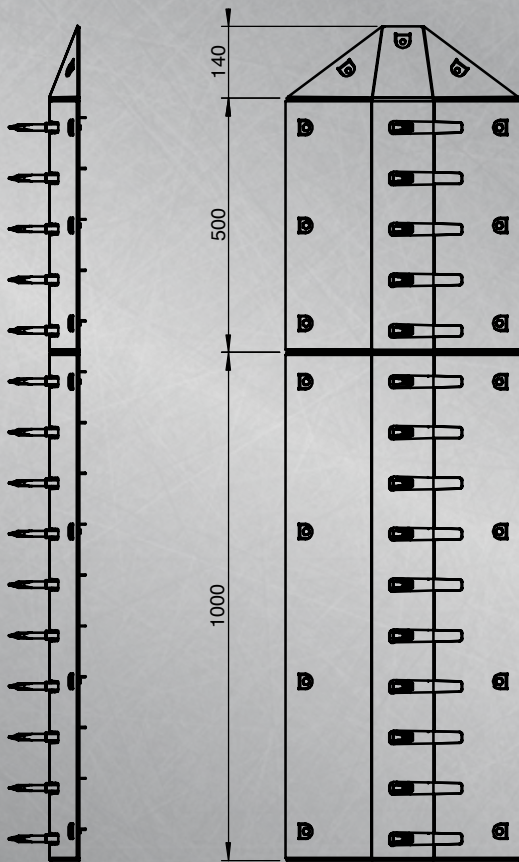

# 12 SAFETY POINTS

Ensure a Safe Installation and  
Reduce Liability with this  
**12 Safety Points on Essential  
“Do’s and Don’ts”**  
of the Single Direction Spike Barrier Installation

While spike barriers effectively protect your assets, control access and manage traffic, there can also be potential risks and liability associated with their use. For this reason, it is extremely important that adequate safety measures are taken in the installation and use of these devices. How a system gets installed will ultimately affect how safe it will be. Since safety is our top priority, we have compiled the following **12 Safety Points** to help you avoid situations and oversights that could result in an unsafe system and create possible liability issues.

✓ **DO CLEARLY WARN PEDESTRIANS AND DRIVERS ABOUT THE POTENTIAL DANGER**

It is crucial that the area be clearly marked with at least a lighted or reflective warning sign. This is strongly recommended and required by law in many areas. Illumination of the teeth, especially in areas of adjacent pedestrian traffic, is highly encouraged. As added protection in high pedestrian traffic areas, a fence could be installed to separate main pedestrian traffic from normal vehicular traffic. Additional signage and pavement markings may also be used to increase awareness of the potential for danger and to reduce property owner’s liability.

✓ **DO INSTALL IN AN AREA THAT HAS HIGH VISIBILITY**

It is extremely important that spike barriers are installed in an area that is highly visible in order to ensure the safety of drivers. They should never be installed in “blind” spots, directly around corners, halfway down a one-way road, or other places where drivers cannot be amply forewarned of the potential for danger.

✓ **DO INSTALL IN SUCH A WAY THAT TRAFFIC FLOWS OVER TEETH AT A STRICT 90° ANGLE**  
Spike barriers **MUST** be installed in such a manner that traffic flows over the teeth at a **STRICT 90°** angle, at the right angle to the teeth. Complete vehicle alignment and the right angle over the spike **MUST** be assured for **BOTH THE FRONT AND REAR TYRES.**

*Failure to follow this guideline may result in extreme wear and tear on the units and in the puncturing of tyres of correct-direction traffic.*

✓ **DON’T INSTALL ON A CURVE**

The problem with installing spike barriers on a curve is that there usually is not enough room allowed before and after the units for all vehicles to cross straight over them. In other words, there must be enough straight roadway available before the units, to allow vehicles that have just completed a turn to straighten out, so that they will approach the units exactly the right angle to the teeth. In addition, there must be enough room after the units, for all tyres of all vehicles to have completely cleared the spike barriers prior to beginning any turns. A good rule of thumb is to allow for 4 – 6 meters in either direction of the spike barrier between any turns that vehicles may be required to take.

*Failure to follow this guideline may result in extreme wear and tear on the units and in the puncturing of tyres of correct-direction traffic.*

✓ **DON’T INSTALL ON UNEVEN OR NON-LEVEL SURFACES**

Surface mount spike barrier must be installed on a level, even surface bumps, or dips beneath them. They must be installed flush with the road surface which must also be level. They must not be installed on an uphill or downhill slope.

*Failure to install surface mount spike barriers on an appropriate level surface, may result in extreme wear and tear on the units and in the puncturing of the tyres of correct-direction traffic.*

Flush mount spike barriers must be installed with a level drainage bed, as per Boomgate Systems instructions. When installed properly, the top plate of a flush mount spike barrier will be level with the road surface. This is crucial to maintaining an optimum tooth angle. Flush mount spike barriers must be level from end to end and from front to back.

*Failure to install flush mount spike barriers levelly, may result in any or all of the following: tyres of vehicles travelling in the wrong direction, NOT being punctured; tyres of vehicles travelling in the correct direction, being punctured; and extreme wear and tear on the units.*

✓ **DO LEAVE ADEQUATE DRAINAGE CHANNELS BELOW FLUSH MOUNT UNITS**

It is important to allow adequate drainage channels below flush mount spike barriers so that water will not accumulate beneath the unit in normal weather conditions.

✓ **DON'T INSTALL ON INAPPROPRIATE ROAD SURFACES SUCH AS BRICK, DIRT, OR GRAVEL**

Spike barriers should only be installed on level concrete or asphalt roadways. Brick, dirt, gravel, or other road surfaces are not appropriate installation surfaces – neither are non-level or extremely worn asphalt or concrete. If installing on asphalt, a combination of bolts and epoxy is recommended when installing surface mount spikes. If spike barriers are needed in an area that has an appropriate road surface, a level concrete pad should be laid at the point of installation.

✓ **DON'T INSTALL IN AN AREA THAT HAS A LOT OF DIRT, DEBRIS, AND GRAVEL**

If the area surrounding the installation has a lot of dirt, debris and gravel, installers are strongly encouraged to lay a concrete pad at the point of installation and the immediately surrounding area, in order to cut down on the amount of these materials getting in to the spike barriers.

*Dirt, debris, gravel, and rock inside the units, as well as improper maintenance, are the main causes of excessive spring breakage.*

✓ **DON'T FORGET TO PROPERLY MAINTAIN THE UNITS**

In order to keep the spike barrier functioning properly, it is essential to be familiar with and to follow through with the maintenance requirements of the units. Proper maintenance consists of periodic inspection and removal of any leaves or material that may have become lodged inside the barrier.

*Neglecting to regularly clean dirt and debris from inside spike barriers, is the number one cause of excessive spring breakage and spike barrier malfunction.*

How often this needs to be done will depend on your geographic area and the conditions at your installation site. Dirt and debris can be hosed or blown out, or can be swept out by removing the top plate, which will allow free access to the interior of the units.

✓ **DO MAKE SURE THE SPIKE BARRIER YOU CHOOSE IS APPROPRIATE FOR THE APPLICATION**

Facilities such as hospitals and emergency rooms, where people are likely agitated and distracted, may not be an appropriate place to install spike barriers. In addition, spike barriers should only be used in a parking situation, or other areas where traffic can be slowed to a maximum of 10 kilometres per hour prior to crossing the units. They are not intended for use on busy roadways where traffic is proceeding at full speed.

*Accidents and extreme wear and tear on the units are possible if traffic is not slowed to an appropriate speed prior to crossing the units.*

✓ **DO ADD SPEED BUMPS BEFORE SPIKE BARRIERS WHEN ADDITIONAL SPEED CONTROL IS REQUIRED AND/OR DESIRED**

If the situation in which the spike barrier is used does not automatically slow traffic down to a maximum of 10 kilometres per hour prior to crossing the unit, then it will be necessary to install a speed bump, prior to the unit, to reduce the speed of approaching traffic. A speed bump may also be installed in any situation where additional speed control is desired, which would also serve to prolong the life of the units.

*Accidents and extreme wear and tear on the units are possible if traffic is not slowed to an appropriate speed prior to crossing the units.*

✓ **DO CONSULT BOOMGATE SYSTEMS FOR OPTIMAL PLACEMENT OF UNITS, BASED ON VARYING ROAD WIDTHS**

The best system and layout for your site will depend on the width of the traffic lane that the units will be installed on. Please call us with your site specifications, so that we can recommend a system and layout that will be appropriate for your lane width. Problems can result from improper spacing of spike barriers across a traffic lane.

**OUR INSTRUCTIONS ARE DESIGNED AND WRITTEN TO PROVIDE THE END USER WITH THE BEST PERFORMANCE POSSIBLE FROM OUR PRODUCTS. FAILURE TO FOLLOW THE INSTALLATION INSTRUCTIONS CAN AND WILL AFFECT THE EFFECTIVENESS, PERFORMANCE, AND SAFETY LEVEL OF YOUR TRAFFIC CONTROLLER.**

**WITH PROPER INSTALLATION AND MAINTENANCE OF BOOMGATE SYSTEMS SINGLE DIRECTION MANUAL SPIKE BARRIER, YOU WILL ENJOY MANY YEARS OF COST-EFFECTIVE AND RELIABLE DIRECTIONAL AND ACCESS CONTROL.**

**BoomGate**  
**Systems** (PTY) LTD

Reg.No. 98/23505/07

Engineering Access Control



**JOHANNESBURG BRANCH: Tel:** +27 11 674 4441 • **Fax:** +27 11 674 4450 • **Email:** boomgate@global.co.za

18 Minerva Avenue, Leaglen, Florida, Roodepoort, SOUTH AFRICA

**CAPE TOWN BRANCH: Tel:** +27 21 551 0849 • **Fax:** +27 21 551 8627 • **Email:** salesci2@boomgatesystems.co.za

Unit 2 Crest Park, 12B Longclaw Drive, Montague Gardens, Cape Town, SOUTH AFRICA

**[www.boomgatesystems.co.za](http://www.boomgatesystems.co.za)**

**Manufacturers & Suppliers of:**

- Traffic Barriers
- High Security Spike Barriers
- Road Blockers
- Turnstiles
- Security Booths
- Pedestrian Barriers
- Paraplegic Gates
- Speed Gates
- Bollards
- Goosenecks
- Magnetic Locks
- Metal Enclosures
- Rubber Islands