



GENIUS™

DROP ARM PEDESTRIAN BARRIER



BoomGate
Systems (PTY) LTD

Reg.No. 98/23505/07 Engineering Access Control



MARKET LEADER

- This versatile product is suitable for most entrance control.
- Boomgate Systems offer a wide range of options to compliment any prestige installation.
- Exported worldwide.

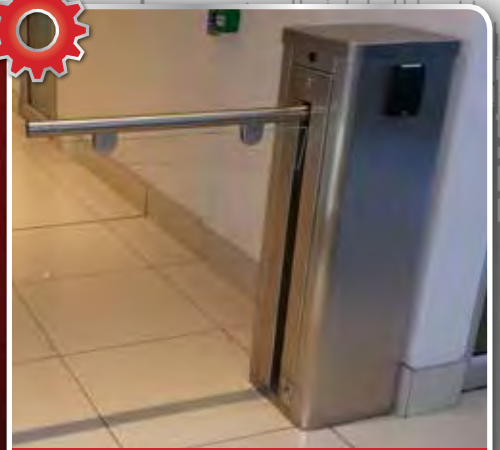

GENIUS™ DROP ARM BARRIER SQUARE



APPLICATIONS:

- To control high volumes at medium risk areas.
- Most suitable: office receptions, colleges and health clubs.
- Suitable for interior installations.



CONFIGURATIONS:

- Euro Style & Square.
- Mild Steel Powder Coated.
- Stainless 304 or 316.
- Granite for tops - for square only.



SECURITY LEVEL RATING: (LOW / MEDIUM / HIGH / ULTRA SECURE)

TYPE	DROP ARM	LOW	MEDIUM	HIGH	ULTRA SECURE
EURO	STYLE	X			
SQUARE	STYLE	X			

DEFINITION

- **Security rating** is based on when the Drop Arm Barrier is in the locked position.
- **Level of security** is based on entry through the Drop Arm Barrier without unlocking the Drop Arm Barrier or use of access control.



GENIUS™ DROP ARM BARRIER - EUR



TECHNICAL SPECIFICATION:

ELECTRICAL REQUIREMENTS:

Power:	220V AC \pm 5%
Frequency:	50Hz
Power Consumption:	80W
Drop Arm Dimensions:	See drawings on overleaf
Drop arms:	38mm Round Tube fixed arms
Weight:	Euro Style 65kg and Square Shape is 50kg
Package size:	Euro Style

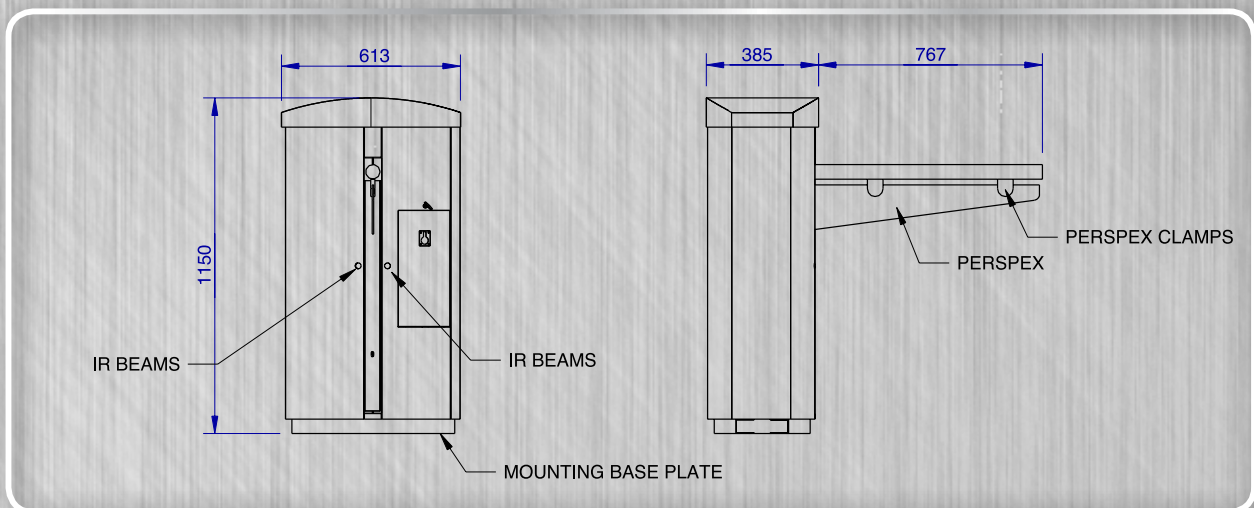

SPECIAL FEATURES TO THE DROP ARM PEDESTRIAN BARRIER

- Designed for long-lasting reliability.
- Modular 11 pin programmable logic with LED indicators.
- Control panel comes standard with 12V output.
- Maintenance free mechanism.
- Factory tested recorded serial numbers.
- Manufacturers warranty
 - 2 year mechanical warranty
 - 1 year electrical warranty
- Zinc plated mechanism for corrosive protection.





AVAILABLE OPTIONS:

ELECTRONICALLY CONTROLLED IN BOTH DIRECTIONS.

Power Locking Options:

Fail safe unlock on power failure.

Fire Evacuation Option:

If input trigger is latched, the drop arm will lower and stay open until the trigger is removed.

Indication LED:

The drop arm can be fitted with red/green walking man to indicate go or stop.

Accessories available on request:

Push buttons, coin acceptors for paid access control, random search selectors.

Material options:

Mild steel powder coated with textured exterior UV resistant powder.

Granite top cover available on request for Square Drop Arm.

304 stainless steel brushed.

316 stainless steel brushed for extreme conditions.

Standard colours for M/S powder coated are Black.

Drop Arm comes standard with 38mm diameter S/S.

304 tube with clear polycarbonate skirt.

Drop Arm can be customised to customers request.



TECHNOLOGY:

- Locally manufactured 100% duty cycle gear torque motor.
- Ultra long lasting double buffer system in all models.
- Plug in microprocessor control logic.
- Safety sensor - available in two options:
 - **Reflective type**
 - **Non reflective type**

SYSTEM COMPATIBILITY:

Boomgate Systems drop arm barriers are compatible with any access control system, time and attendance system or ticketing system. Only requires a n/o voltage free input trigger set for half a second.



GENIUS® PEDESTRIAN DROP ARM BARRIER



SQUARE DROP ARM BARRIER

EURO STYLE DROP ARM BARRIER

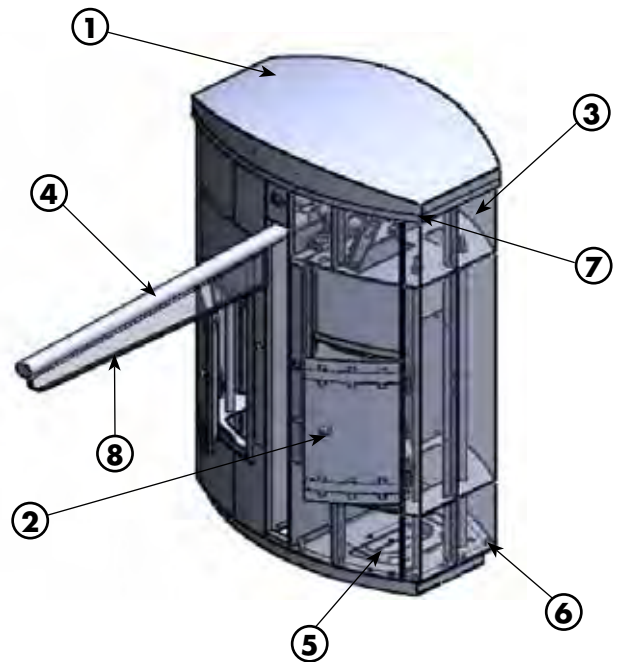
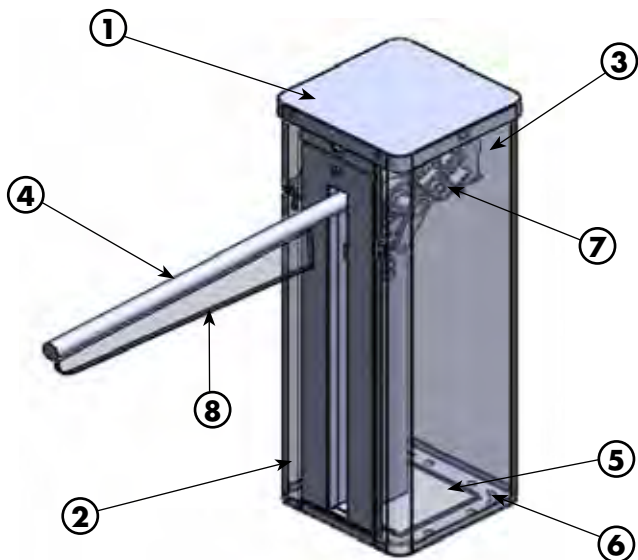

1	Removable Lid	5	Cable entry
2	Lockable and removable door	6	Floor fixing position 4 x M12 Rawl bolts
3	Reader mounting position	7	Motor drive
4	38mm Round tube stainless steel arm	8	Polycarbonate skirt





GENIUS® PEDESTRIAN DROP ARM BARRIER



SQUARE DROP ARM BARRIER

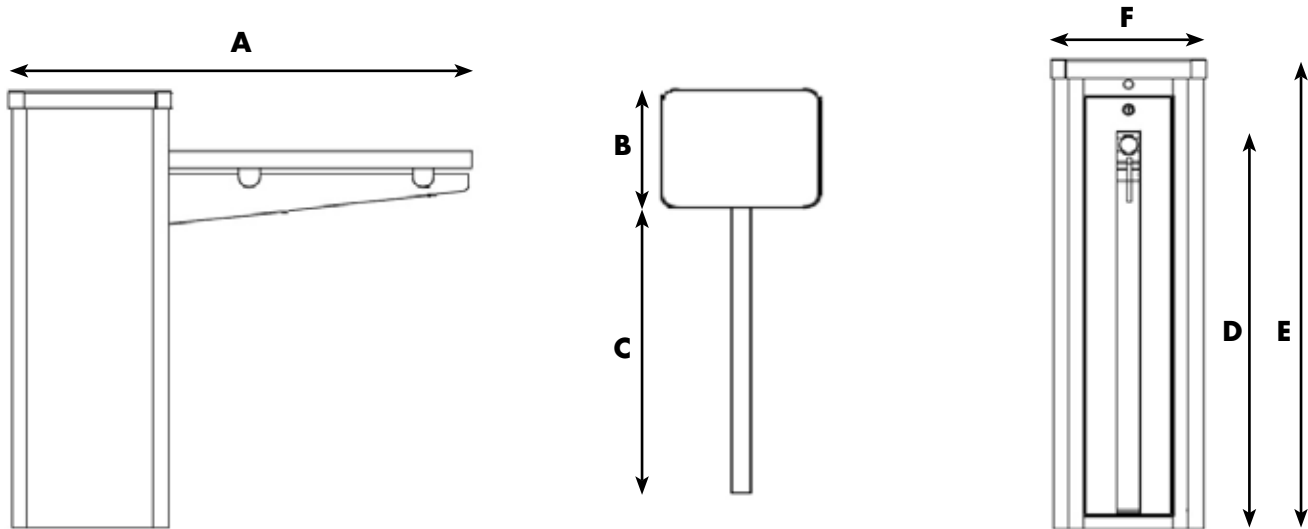

EURO STYLE DROP ARM BARRIER

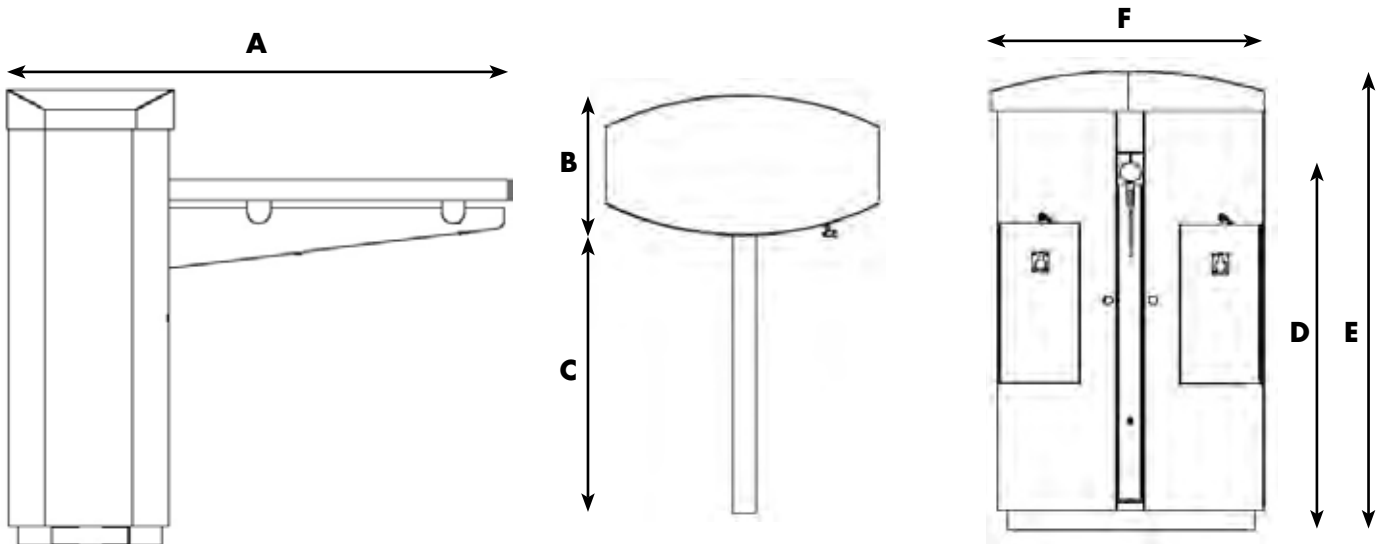

SQUARE DROP ARM BARRIER

A	Total Width	1070mm
B	Housing Depth	332mm
C	Drop Arm Length	738mm
D	Drop Arm Height	856mm
E	Overall Height	1059mm
F	Overall Width	332mm

EURO STYLE DROP ARM BARRIER

A	Total Width	1152mm
B	Housing Depth	385mm
C	Drop Arm Length	767mm
D	Drop Arm Height	856mm
E	Overall Height	1150mm
F	Overall Width	613mm

Due to continuous improvement, products and design are subject to change without notice.





BoomGate[®]
Systems (PTY) LTD

Reg.No. 98/23505/07

Engineering Access Control



JOHANNESBURG BRANCH: Tel: +27 11 674 4441 • **Fax:** +27 11 674 4450 • **Email:** boomgate@global.co.za

18 Minerva Avenue, Leaglen, Florida, Roodepoort, SOUTH AFRICA

CAPE TOWN BRANCH: Tel: +27 21 551 0849 • **Fax:** +27 21 551 8627 • **Email:** salesct2@boomgatesystems.co.za

Unit 2 Crest Park, 12B Longclaw Drive, Montague Gardens, Cape Town, SOUTH AFRICA

www.boomgatesystems.co.za

Manufacturers & Suppliers of:

- Traffic Barriers • High Security Spike Barriers • Road Blockers • Turnstiles • Security Booths • Pedestrian Barriers
- Paraplegic Gates • Speed Gates • Bollards • Goosenecks • Magnetic Locks • Metal Enclosures • Rubber Islands