



TYPHOON™

SPECIAL NEEDS GATE

SEMI-AUTOMATED



BoomGate®
Systems (PTY) LTD

Reg.No. 98/23505/07

Engineering Access Control



MARKET LEADER

- Semi-automated.
Push to open, auto to close.
- Aesthetically pleasing.
- New design.
- Custom made on request.



APPLICATIONS:

- Our Special Needs Gate is designed to offer reliable controlled access such as guarded lobbies, reception areas, museums, libraries and health clubs.
- The gates are suited for in conjunction with our top range of turnstiles, meeting the additional access needs of items such as trolleys, wheelchairs and baby buggies.
- Suitable for:
 - Interior Installation
 - Exterior Installation – must be covered



CONFIGURATIONS:

- 90° left hand or right hand opening.
- 180° opening – most popular model. Also comes standard with manual override key.
- Framed stainless steel gate with laminated safety glass.
- Frameless: 10mm Toughened glass gate.



SPECIAL FEATURES:

- Comes with a 2 year mechanical warranty and 1 year electrical warranty.
- Manual override.
- Key for 180° gate.
- Gate open monitor.
- Gate hold open at 90° is standard.
Gate close non hold open on request.





TECHNICAL SPECIFICATION:

ELECTRICAL REQUIREMENTS:

Power:	220V AC \pm 5%
Frequency:	50Hz
Power Consumption:	15W
Control Logic:	12V DC
Mechanism:	90° gate c/w 300kg magnetic lock 180° gate is solenoid controlled and c/w manual override key
Gate frame:	38mm S/S tube with glass clamps and 6mm SABS toughened glass
Frameless gate:	10mm SABS toughened glass
LED indicators:	Mounted on top of gate port. Red and Green
Fail safe:	Gate unlocks on power failure
Fail secure:	Gate locks on power failure. This option comes with manual key override.

90° SWING GATE - LEFT HAND

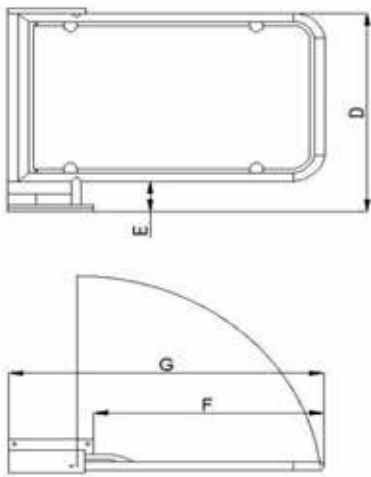

90° SWING GATE - RIGHT HAND

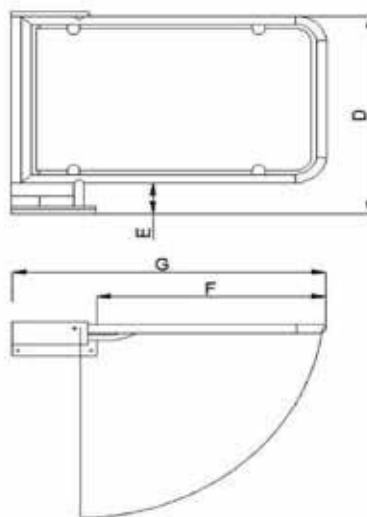

180° SWING GATE - RECTANGULAR

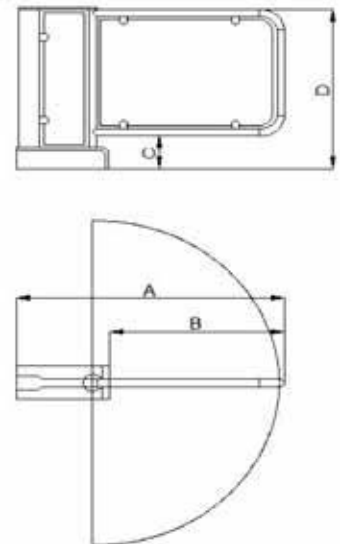

90° SWING GATE

G	Total Width	1 280mm
F	Opening Size	860mm
E	Gate from floor	140mm
D	Total height	930mm

180° SWING GATE

A	Total Width	1 280mm
B	Opening Size	840mm
C	Gate from floor	190mm
D	Total height	930mm

*Due to continuous improvement, products and design are subject to change without notice.

**Available in mild steel powder coated and stainless steel brushed.



BoomGate[®]
Systems (PTY) LTD

Reg.No. 98/23505/07 Engineering Access Control



JOHANNESBURG BRANCH: Tel: +27 11 674 4441 • Fax: +27 11 674 4450 • Email: boomgate@global.co.za

18 Minerva Avenue, Leaglen, Florida, Roodepoort, SOUTH AFRICA

CAPE TOWN BRANCH: Tel: +27 21 551 0849 • Fax: +27 21 551 8627 • Email: salesct2@boomgatesystems.co.za

Unit 2 Crest Park, 12B Longclaw Drive, Montague Gardens, Cape Town, SOUTH AFRICA

www.boomgatesystems.co.za

Manufacturers & Suppliers of:

- Traffic Barriers • High Security Spike Barriers • Road Blockers • Turnstiles • Security Booths • Pedestrian Barriers
- Paraplegic Gates • Speed Gates • Bollards • Goosenecks • Magnetic Locks • Metal Enclosures • Rubber Islands