

MOSAIC

BY **NICAS**

leading in LUXURY

table of contents

1. Introduction
2. What Makes Mosaic Unique
3. The Freedom of Customization
4. Mosaic Dispenser Models
5. Ease of Use — Open Refillable System
6. Ease of Use — Closed Cartridge System
7. Refillable (Open System) — Wall Mount Dispenser
8. Cartridge (Closed System) — Wall Mount Dispenser
9. Mosaic in Use Around the World
10. Approved Brands
11. Volume and Usage
12. Manufacturing
13. Materials
14. Pump
15. Ease of Installation
16. Highlights and Dimensions
17. Print Specs
18. Testimonials
19. Unique Environmental Advantages of Mosaic
20. Warranty



MOSAIC

introduction

MOSAIC was designed and developed for use exclusively in *boutique 3-star and luxury 4 and 5 diamond guest rooms.*

It is our belief that an elegant and sophisticated dispenser system is increasingly important to luxury hotels needing to be proactive in reducing waste and operational costs.

We also believe the dispenser, and the product within, need to work in the best interests of the property and its valued guests. With this in mind, MOSAIC is uniquely customizable.

what makes mosaic unique

Bathroom Fixture, not a bottle & bracket attachment

Meaningful environmental advantages

Manufactured in North America

Hi-resolution digital printing

No plastic shrink wrap

No paper stickers

No decals

Customizable

Ease of Installation

Ease of Cleaning and Maintenance

Robust proprietary pump

Eastman Tritan Copolyester Material

Warranty



the freedom of customization

Mosaic is fully customizable with an almost endless choice of colours to match your hotel décor, whether classic or rustic elegance, eco-chic, traditional or contemporary, chain or independent.

Mosaic's design flexibility allows for precise customized branding.

the freedom of customization



MOSAIC DISPENSER MODELS



ease of use — open refillable system



Compact Design

Dimensions:
5.1" x 2.2"x 5.3"
Capacity:
19 oz / 570 mL



Fluid Indicator

For easy viewing of liquid level inside and when to replenish.

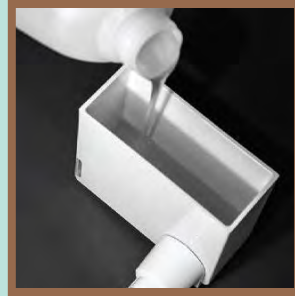

Quick Refill

Large lid opening allows for an easy refill of the vessel.



Tamper Proof Lock

Safeguards dispenser contents – and your guests experience.



Specialized Security Key

Fits into the bottom of dispenser surround and releases vessel.



Easy Removal

Collar serves as a handle for effortless removal.

ease of use — closed cartridge system



Compact Design

Dimensions:
5.1" x 2.2"x 5.3"
Capacity:
19 oz / 570 mL



Fluid Indicator

For easy viewing of liquid level inside and when to replenish.



Cartridge Replacement

Insert cartridge into dispenser vessel.



Tamper Proof Lock

Safeguards dispenser contents – and your guests experience.



Specialized Security Key

Fits into the bottom of dispenser surround and releases vessel.



Easy Removal

Collar serves as a handle for effortless removal.

open refillable system — WALL MOUNT DISPENSER



Open System

Description – 19 oz / 570 mL

Wall Mount (screws not required)

Tamper proof lock component

CLOSED cartridge system — WALL MOUNT DISPENSER

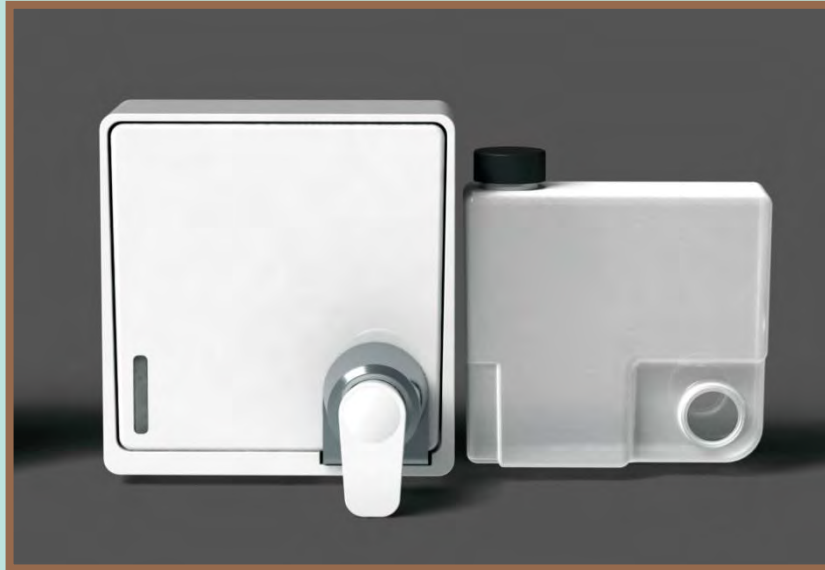

Closed System

Description – inner replaceable sealed cartridge 14.2 oz / 414 mL

Wall Mount (screws not required)

Tamper proof lock component

Eastman Tritan™ copolyester material

Replaceable recyclable HDPE inner cartridge

MOSAIC AROUND THE WORLD

100,000+ MOSAIC dispensers are found in over 21 countries, in many properties including, among others:

Lenox Hotel (Boston)

Fairmont Royal York (Toronto)

Opus Hotel (Vancouver)

Coquille Hotel – Relais & Chateau (France)

Mandarin Oriental (Munich)

The Xperience Hotel (Mazatlan)

Metro Hotel (San Francisco)

Rosedon Hotel (Bermuda)

Siloso Island Resort (Singapore)

Hotel Albana (Zermatt, Switzerland)

Kurhotel Skodsburgh (Denmark)

Government Diplomatic Hotel (Hong Kong)

Espresso Hotel (Milan)

Dylan Hotel (NYC)

Aava Hotel (Whistler)



MOSAIC

approved brands

MOSAIC is approved for use by the following luxury brands and is continually adding new premium brands:



ABAHNA™



BEEKMAN
1802



LATHER®

(MALIN+GOETZ)

NEST
NEW YORK

ONEKA

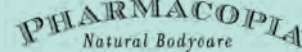

portico



skoah.®



WILLIAM ROAM

Z E N T S

VOLUME AND USAGE



Volume

- Open/Refillable: 570 mL – 19 oz
- Closed/Cartridge: 414 mL – 14.2 oz

Usage – Based on 85% occupancy

- On average replenishment is every 3–4 weeks
- Once liquid level is visible in fluid indicator window, enough product remains for 5–7 days
- Easy to install, remove, refill and or exchange, clean and lock

manufacturing



Manufacturing

- Designed and Manufactured in North America.
- Our manufacturing adheres to strict labor and environmental standards.
- We use first world state-of-the-art production and manufacturing processes.

materials



MOSAIC is manufactured using Eastman Tritan™ Copolyester. The benefits of Eastman Tritan Copolyester include:

- A more efficient manufacturing process, reducing energy consumption
- BPA free
- Widely used in food equipment and housewares products
- Approved for use in food safe applications, including baby food products. E.g.: baby bottles, food containers, blenders
- Shatter resistant
- Durable
- High gloss finish
- Easy to clean
- Customizable colors
- A far superior material over lower-cost alternatives such as polycarbonates and acrylics

pump



Pump

- A new, proprietary pump designed and manufactured by JRS Amenities with a one-year warranty
- Each pump delivers 2 cc of product
- Pump is replaceable
- Spring is stainless steel with a push pound rate of 6.7 lbs and actuation lifespan of over 1 million pumps.
- Tested to over 80,000 compressions without failure, representing over 10 years of operational use.

ease of installation

- No screws required
- Industrial two-sided tape supplied for positioning assistance
- Waterproof silicone sealant adhesive required for attachment
- Can be removed after installation and reattached for any reason, i.e., renovation

What's Included

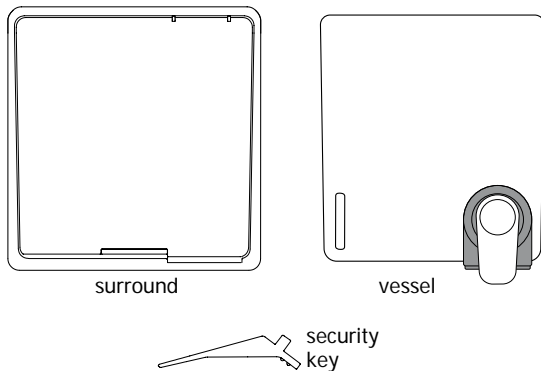

Installation

- 1: Determine where you are going to mount MOSAIC. Ensure mounting surface is cleaned well to remove any dirt or debris.

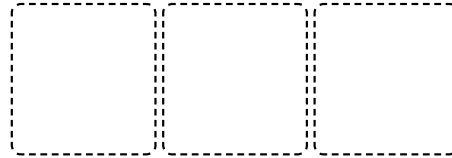

(typical arrangement for three units)

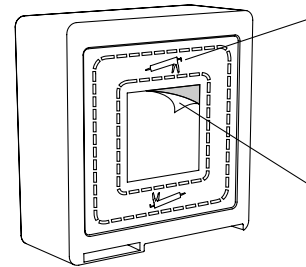

- 2: Apply a waterproof silicone ADHESIVE appropriate for your mounting surface to the indicated area on the back of the surround.

- 3: Remove the double-sided tape backing and apply hand pressure to the inside centre of the surround against the wall. Use a level to ensure the surround is straight. Allow the adhesive to fully cure (per product instructions) before inserting the filled vessel.

- 4: Once the adhesive has set*, slide the filled vessel back into the surround and push/ click the collar to lock into place.

*Refer to adhesive product guidelines for required dry/ cure time.

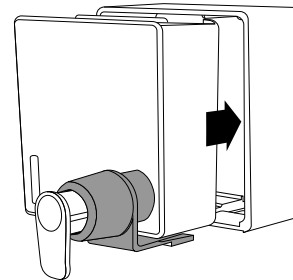

Fill Procedure – Open Refillable System

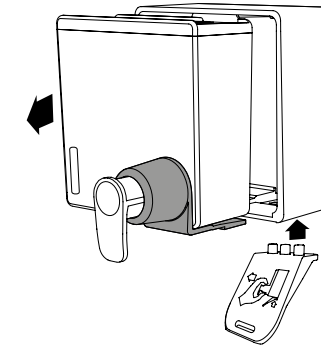

- 1: Insert the security key into the holes on the underside of the surround while pulling on the collar to remove the vessel.

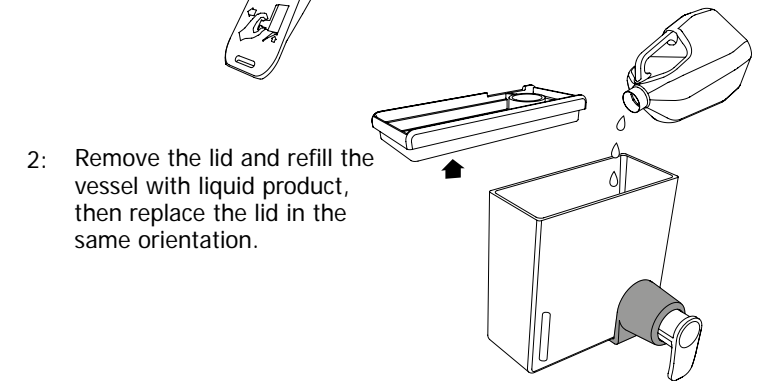

- 2: Remove the lid and refill the vessel with liquid product, then replace the lid in the same orientation.

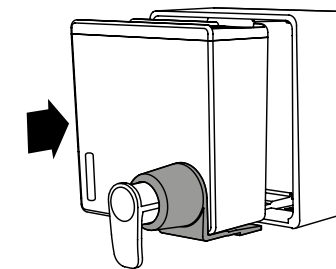

- 3: Push the vessel back into the surround and click into place.

ease of installation

(continued)

Fill Procedure – Closed Cartridge System

- 1: Insert the security key into the holes on the underside of the surround while pulling on the collar to remove the vessel.

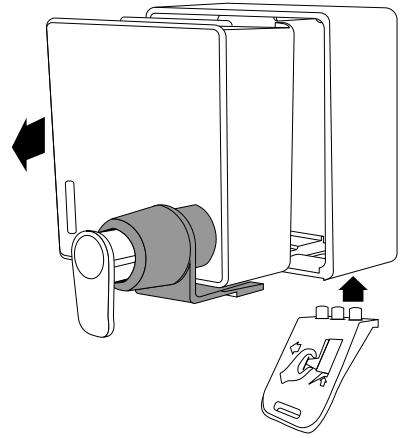

- 2A: Turn the nozzle to the right to unlock pump...

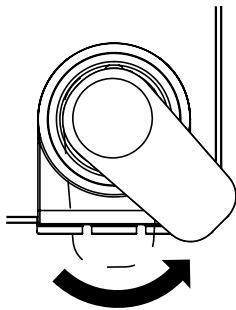

- 2B: ...and pull out collar and pump together.

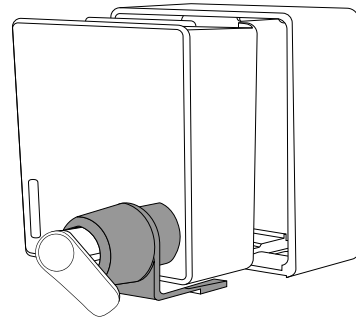

- 3: Remove white cylinder stopper from black rubber seal and place filled cartridge into vessel. Unscrew cap and remove/puncture foil seal.

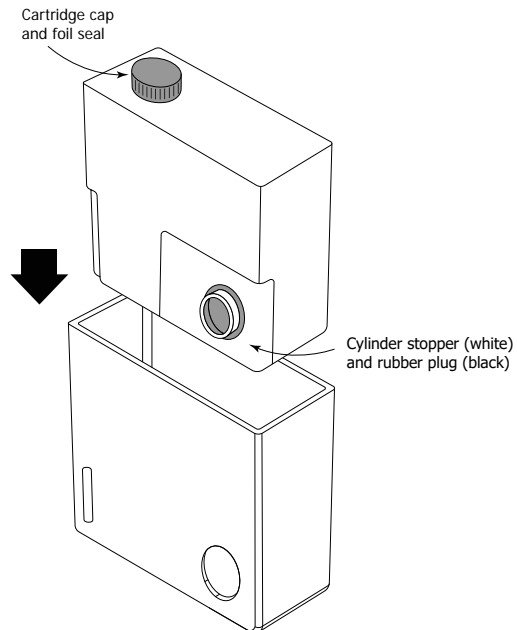

- 4A: With nozzle twisted to the right, replace pump into vessel.

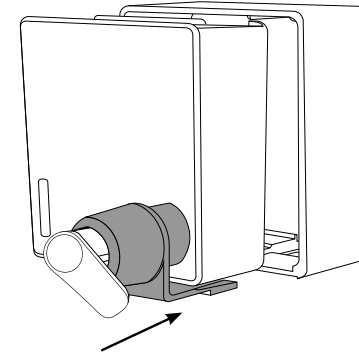

- 4B: Once in place turn nozzle to the left to lock. Pump nozzle to break rubber seal.

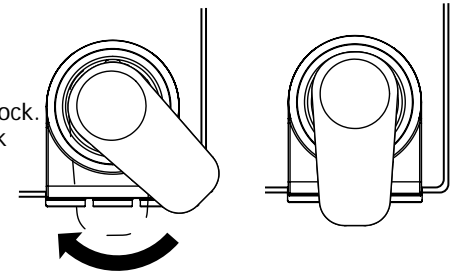

- 5: Slide the filled vessel back into the surround and push/click the collar to lock into place.

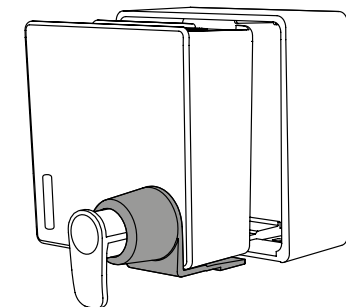

highlights and DIMENSIONS

Highlights

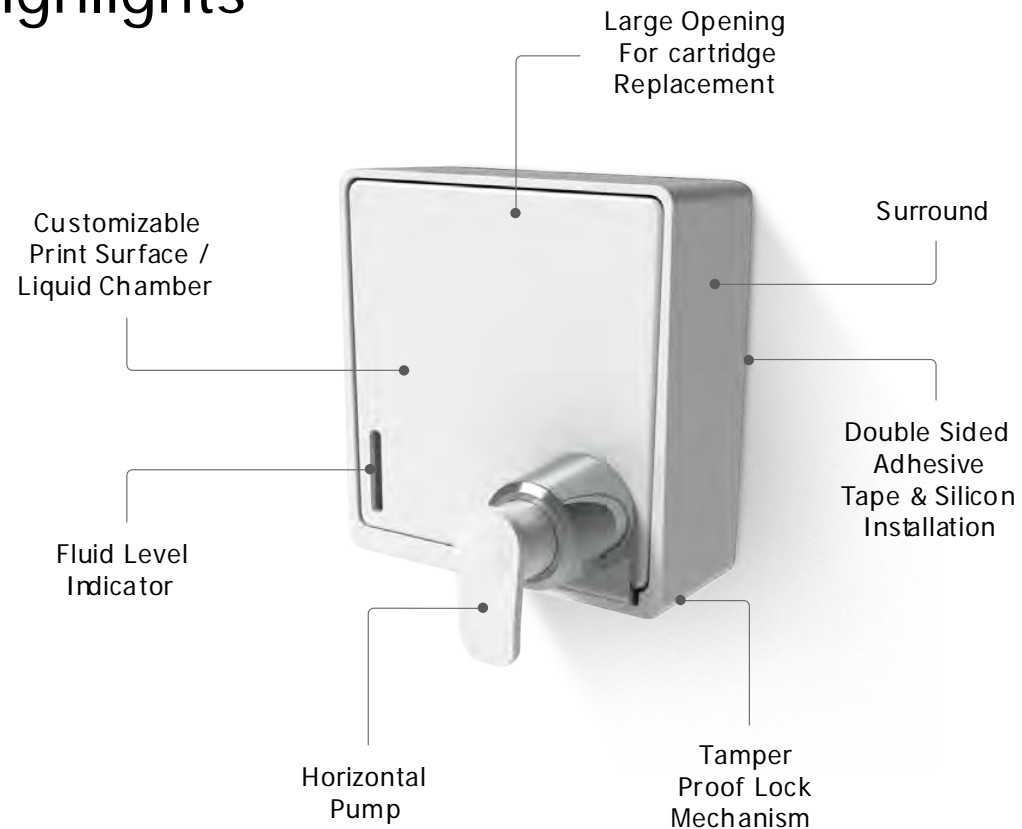

Dimensions & Volume



Dimensions

5.1" x 2.2" x 5.3"

Liquid volume

Open/Refillable System: 570 mL / 19 oz

Closed/Cartridge System: 414 mL / 14.7 oz

PRINT SPECS

For Use by Your Brand Design Team
MOSAIC does not use labels, decals or stickers.

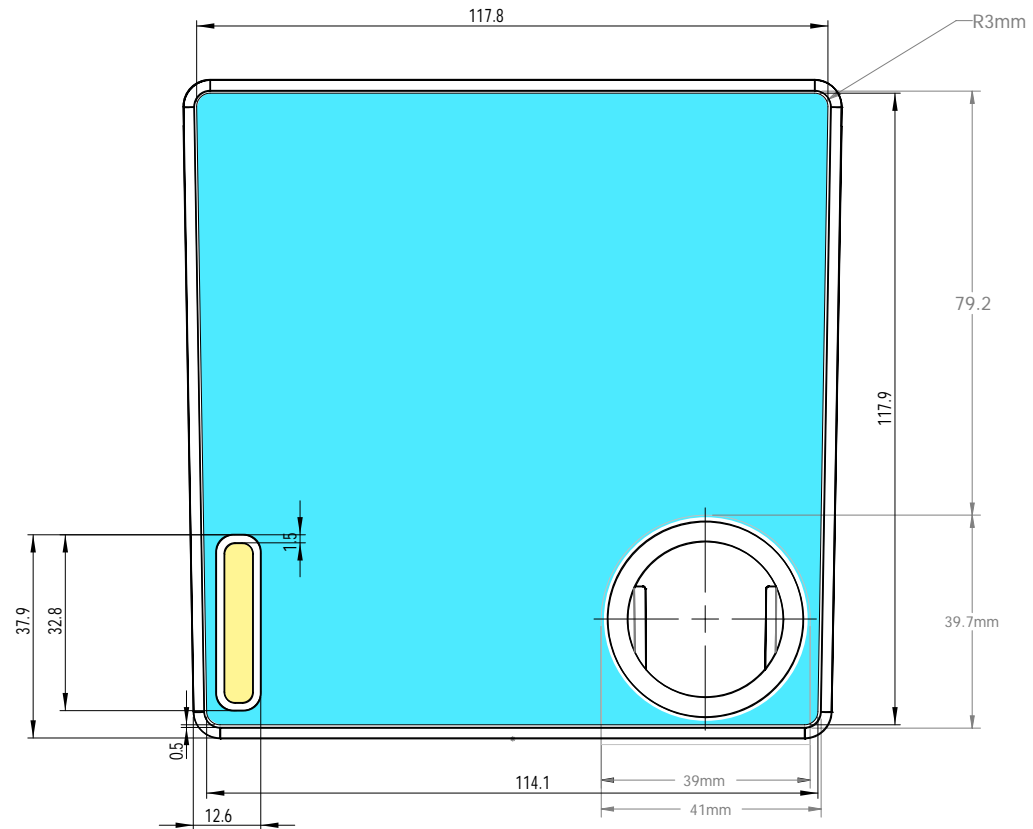
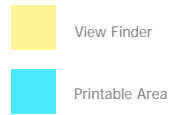

testimonials

// We searched for a high-end unit to put into the bathrooms of our historic, luxury hotel, The Lenox... Sleek, luxurious, intuitive and tamper proof, this amenity dispenser is the only one that we could pair with a luxury amenity line to pamper our guests... The functionality and durability are second to none. //

Scot Hopps

Director of Sustainability, The Lenox Hotel, Boston, MA

// At the Opus, we had been looking for a dispenser solution for our amenity program, but had yet to find one that would complement our style. When MOSAIC was introduced to us we realized we had found the system we had been looking for. //

Nicholas Gandossi

General Manager, Opus Hotel, Vancouver, British Columbia

// Design is paramount to the Malin+Goetz experience... That's where the MOSAIC Dispensers come in. The fixtures are modern and minimal in design and incredibly easy to install and maintain... Good design always looks good—great design does good. //

Andrew Goetz

President, (MALIN+GOETZ) Modern Apothecary and Lab, New York

// The Mosaic dispenser system is going to revolutionize the hotel amenity space. With dual ability to customize the labeling and reduce reoccurring waste, it's a no brainer for any hotel operator //

Ethan Orley

Owner Operator, Hotel Clermont

UNIQUE ENVIRONMENTAL ADVANTAGES OF MOSAIC

Plastics Savings Metric

Analysis of 50 mL bottle program vs. MOSAIC refillable open system

250 room property @ 70% annual occupancy

50 mL Total Bottles: 113,400 pcs / 5,670,000 mL

Total Plastic: 1,134,000 g

Total 5 L Jugs: 1,118 pcs / 5,670 L

Total Plastic: 265,047 g

Plastic Savings over 12 months: 869 kg

Analysis of 50 mL bottle program vs. MOSAIC cartridge closed system

250 room property @ 70% annual occupancy

50 mL Total Bottles: 113,400 pcs / 5,670,000 mL

Total Plastic: 1,134,000 g

Total 14 oz Cartridge: 13,5000 pcs / 119,725 oz

Total Plastic: 744,930 g

Plastic Savings over 12 months: 389 kg

Assumptions:

250 Room Hotel @ 70% annual occupancy

63,000 50 mL Shampoo 50 mL bottles

63,000 50 mL Conditioner 50 mL bottles

63,000 50 mL Body Wash 50 mL bottles

Definitions:

50 mL @ 10 g: Includes Bottle + Cap

Cartridge @ 55.18 g: Includes Cartridge (51 g) + Cap (0.18 g) + Rubber Plug (4 g)

5 L bulk size @ 237 g: Includes jug + cap

Conversion:

1,000 g = 1 kg

1 US ton = 907,185 g

1 oz = 30 mL

WARRANTY

NICAS INDUSTRIES SDN BHD. warrants to the original purchaser of each MOSAIC™ Dispenser that all parts shall be free from defects in material and workmanship under normal use and service for a period of one (1) year from the date of shipment to the original purchaser. MOSAIC™ Dispensers are rated for products within a viscosity range of 150mPas-50,000mPas. NICAS INDUSTRIES SDN BHD cannot guarantee proper operation of the dispensers if your product falls outside this range. Use of products outside of the approved viscosity range shall invalidate all warranties contained herein. The warranties defined herein shall not apply to any damage or defects created or arising from accident, misapplication, abuse, misuse (including use of cleaning products with hydrogen peroxide above 3%), neglect,

alteration, acts of God, vandalism, flood, fire or any other occurrences beyond the control of NICAS INDUSTRIES SDN BHD.

Claims under the forgoing warranty will be honoured only if NICAS INDUSTRIES SDN BHD. (i) has received the entire payment of the purchase price for the product with respect to which any such claim is made, (ii) has received notification of the claim prior to the expiration of the one (1) year warranty period described above, (iii) has received the returned product delivered duty paid and the detailed description of the defect, and (iv) determines upon examination of the returned product that it is defective under the terms of such warranty.

NICAS INDUSTRIES SDN BHD's sole obligation under the forgoing warranty and for other claims related to any product shall be limited to, at

NICAS INDUSTRIES SDN BHD'S option, (i) repairing or (ii) replacing, any product which NICAS INDUSTRIES SDN BHD. determines is defective under the terms of such warranty. The foregoing warranty and remedies are exclusive and in lieu of any other warranties and remedies whatsoever, expressed or implied, including but not limited to any implied warranties of merchantability or fitness for a particular purpose, all of which NICAS INDUSTRIES SDN BHD. hereby expressly disclaims.

NICAS INDUSTRIES SDN BHD. Is not responsible for incidental or consequential damages of any kind, including but not limited to lost profits, downtime, goodwill or damage to equipment or property.

THANK YOU!

NICAS INDUSTRIES SDN. BHD.

No. 32, Jalan 34/10A,
Taman Perindustrian IKS,
Batu Caves 68100.

Kuala Lumpur, Malaysia.

Tel: +603 6730 9697

+6017 221 3397