

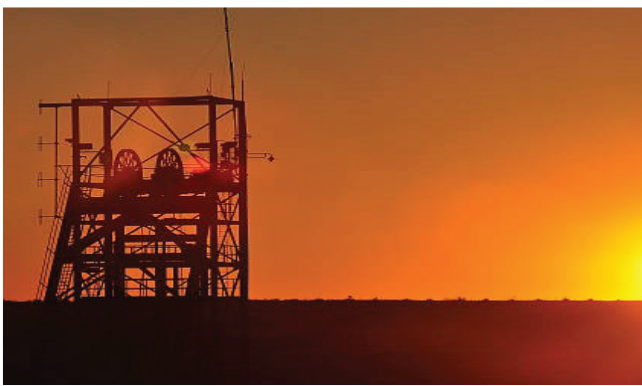

Carl Hamm
Pipes | Pumps | Solutions



**EXCELLENCE IN
PUMPS**
For the Mining and
Metallurgical Industries



FELUWA in the Mining and Metallu

Autoclave Feeding

Various methods are applied for the extraction of ore from minerals. Many ores require high pressure, high temperature, low pH value or a combination thereof. Acid leaching of the ore by means of pressure acid leaching (PAL) or high pressure acid leaching (HPAL) rank amongst the favoured treatment options. Dependent on the individual systems, slurries are fed at different temperatures into autoclaves or digesters. In the majority of cases diaphragm piston pumps are applied for such duties. Typical specifications for autoclave feeding are pressures in excess of 40 bar, high solid concentrations, low pH values and pumping temperatures of up to 230 °C, whereas digester feeding is subject to higher pressures in a range of 100 bar and pH values of 11 to 13.

Due to their unique design, FELUWA hose-diaphragm pumps are particularly conducive to autoclave and digester feed applications in metallurgical processes such as alumina, copper, gold, molybdenum, nickel, uranium or zinc. Since the slurry is in contact with the inside of the



Autoclave feeding, using single-acting FELUWA MULTISAFE® double hose-diaphragm pump in triplex configuration.

hose-diaphragm and the check valves only, diaphragm housings can be made from lesser materials, and are therefore more economical to manufacture and procure.

Tailings Transfer



Metallurgical extraction processes are associated with enormous amounts of waste materials that require safe disposal. As an example in aluminium facilities 6 to 7 tonnes of red mud at high pH value accrue from a single tonne of bauxite. In gold processing, only a few grams of gold can be extracted from a tonne of ore. The resulting waste materials are usually pumped to tailings ponds at low concentrations.

FELUWA pumps (FP) provide for the environmentally friendly transportation of red mud and other tailings at solids concentrations of up to 70% with associated high efficiency as well as low power and wear.

Each of the six FELUWA MULTISAFE® pumps transfers red mud at 95 m³/hr and 120 bar pressure at an alumina refinery in China.

Mineral Industries



Carl Hamm
Pipes | Pumps | Solutions

Underground mines require effective dewatering in order to prevent flooding. Mine water contains all manner of contamination and solids. Traditional dewatering systems require large underground settling ponds to separate solids from fluid. The relatively clean water is pumped to the surface by means of centrifugal pumps in several stages. Traditional settling ponds require space and maintenance and centrifugal pumps are subject to low efficiencies and high wear. Nowadays solids are transported from below ground by alternative means.

FELUWA MULTISAFE® double hose-diaphragm pumps offer a most profitable alternative solution to multi-stage centrifugal pumps. They are not only capable of pumping unsettled mine effluent to the surface in a single stage, but likewise ensure maximum efficiency and minimum wear. Settling ponds can be avoided and solids are removed with the mine water.



Moreover, cylindrically shaped hose-diaphragm pump heads allow for a considerably smaller footprint and pump room than traditional diaphragm pumps and accordingly reduced excavation cost.

Mine Dewatering

Concentrate Pipeline Transfer

Pipeline transfer of coal, ore or concentrate is increasingly replacing transportation by means of rail, road or long distance conveyor belt systems. Pipelines require less space and can be laid underground. Particularly in rugged mountainous areas that do not allow for transportation by road or rail, pipelines are the sole feasible method of conveyance. Pipelines are environmentally friendly and require little power, labour and maintenance. In the majority of cases the cost of ownership of pipeline slurry transfer systems therefore is an attractive alternative to traditional transportation methods.



*The biggest FELUWA hose diaphragm piston pump.
Flow rate 260 m³/hr at a discharge pressure of 100 bar.*

About FELUWA Pumps

FELUWA pumps are available for flow rates of up to 1,350 m³/h and discharge pressures of up to 350 bar. They are characterised by unique design features in favour of the overall performance, reliability, availability and cost of ownership. Some of these features are:

FELUWA Double Hose-Diaphragms

At the heart of FELUWA MULTISAFE® pumps are two hose-diaphragms which are arranged one inside the other. They fully enclose the linear flow path of the product and provide for double hermetic sealing from the hydraulic drive end. The lifetime of hose-diaphragms is considerably extended beyond that of flat diaphragms. Standard materials are available for temperatures up to 200 °C.

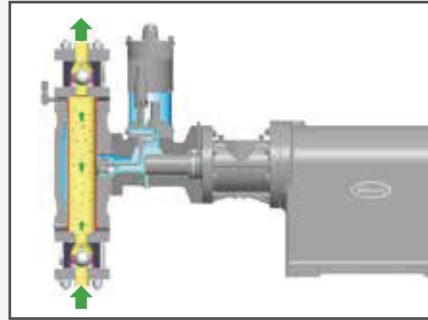

FELUWA DownFlow Technology (DFT)

For applications carrying solids that tend to settle and may cause breakdown of the pump resulting from blockages within the check valves, pump chamber or piping, FELUWA literally turns the traditional pumping principle upside down. By means of downflow configuration the flow is led from the top to the bottom of the pump. Sedimentation within the pump is thus reliably prevented.

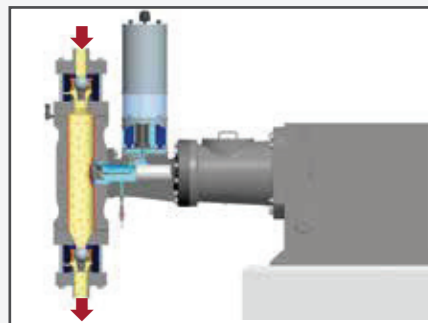

FELUWA Double Valves and Quick Change System (QC)

Double valves with unique hydraulic clamping system (QC) are recommended for media with high solid content and applications which require a particularly high continuous flow. If, in the short term, a particle gets jammed between the ball or cone and the valve seat resulting in valve leakage, the second valve ensures effective sealing, thus preventing medium backflow and a resulting loss of volume.



FELUWA Pulsation Dampener

With displacement pumps the oscillating movement of the pistons may result in undesirable flow fluctuation and pressure pulsation. For conveyed fluids which do not allow for a contact with the air cushion in the pulsation dampener and for high pressure applications, FELUWA applies various options for pulsation dampening.

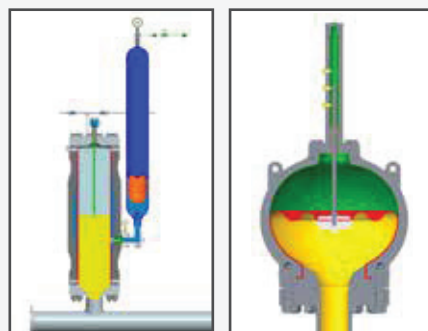

FELUWA WebGuard (FWG)

By means of diagnostic systems and touch panels, FELUWA offers a Human Machine Interface with full integration of pump diagnostics into industrial control systems and also a web-based service option. Permanent monitoring includes for example hose-diaphragms, check valves, inlet and discharge pressure, flow rate, speed, pulsation, hydraulic oil temperature, lube oil flow and pressure.

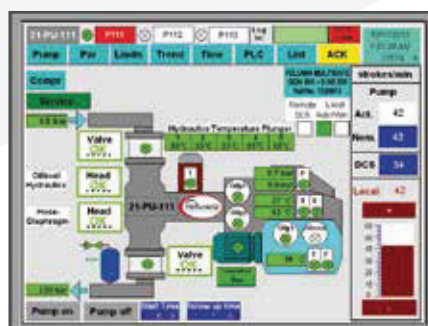



About FELUWA

FELUWA Pumpen GmbH has at its base in excess of 100 years' corporate history. In 1901, the parent company was established in Neuwerk/Mönchengladbach as a foundry and expanded in 1931 by the addition of a machine factory, based in Cologne. At that time, the company focused on the production of equipment of fire, air and water technology. The company name FELUWA is derived from the German words for the former business operating areas "fire" (**FEUER**), "air" (**LUFT**) and "water" (**WASSER**).

After a relatively short period of time, the company started concentrating on pump technology. In 1960, the company moved to Mürlenbach in the Eifel area. The integration of FELUWA Pumpen GmbH into the ARCA Flow Group in November 2000 provided the opportunity for further global growth. For in excess of 80 years, ARCA Regler GmbH has been one of the lead-

ing manufacturers of control valves, pneumatically activated actuators and positioners. With a diverse range of control valves, pumps and level indicators the ARCA Flow Group is firmly established in various fields of operation, such as chemical, petrochemical, power plants and synthesis gas plants, oil and gas, mining, food industries.

The continuous process of innovation and development of FELUWA Pumpen GmbH has been subject to multiple high-ranking recognition and awards.

The total company land area exceeds 100,000 m², including more than 9,350 m² of building area for production and office facilities. FELUWA is continuously expanding and investing in new machinery and production halls in order to ensure constant and optimum quality standards.

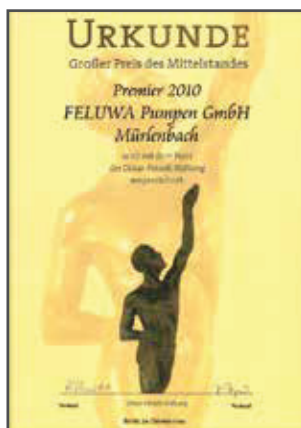

Premier
Grand Prix of Medium-Sized Enterprises



Plaque of Honour
Grand Prix of Medium-Sized Enterprises



Frost & Sullivan
Best Practices Award



Carl Hamm

Pipes | Pumps | Solutions

Competence, experience, innovative thinking, modern manufacturing plants and motivated employees form the basis of our services.

With the flexibility of a modern, medium-sized company and the experience of our over 90-year history, we are well equipped to meet the requirements of the future.

The numerous certifications and technical approvals of course ensure that we serve our customers with the highest quality standards through the complete project phases.

Our product range focuses on water, waste water and power industries, tunnel construction and well sinking as well as open-pit and underground mining.

We as a competent partner ensure an added value for the specific customer needs: from the conceptual planning to professional production and punctual delivery.



Headquarters of Carl Hamm in Essen, Germany

Röhrenwerk Kupferdreh Carl Hamm GmbH

Gasstraße 12
D-45257 Essen
Germany

dieter.schmitz@carl-hamm.com
www.carl-hamm.de
Tel.: +49 (021) 848 1723
Fax: +49 (201) 848 1770
Mobile: +49 (151) 503 12104

Carl Hamm PPS (Pty.) Ltd

2 Bickford rd, Founders Hill, Kempton Park, Gauteng
PO Box 1492, Boksburg, Germiston, 1460
South Africa

chris@carl-hamm.co.za
www.carl-hamm.co.za
Tel.: +27 (0)72 256 0926